

TOPENS[®]

CK1200

Installation Manual

For sliding gate installation

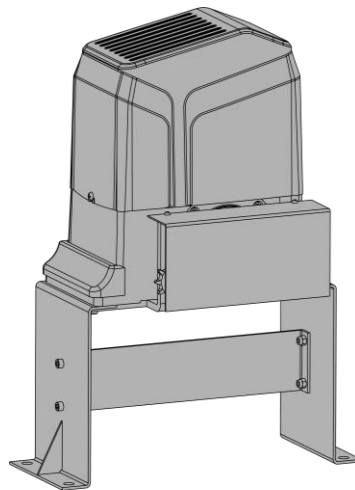

Installation Video



The opener can be powered by AC electricity ONLY.

CONTACT US

For Technical Support and Installation Assistance

Visit our website at www.topens.com and fill out the online form

Alternatively, you can send an email to our service team at support@topens.com

To ensure prompt and effective assistance, kindly include the following information in your email:

- **Where Did You Purchase?** _____
- **Order Information** _____
- **Your Contact Information** _____
- **Gate Information (Weight and Length)** _____
- **Did You Purchase Any Accessories? (If Yes, Please List Them)** _____
- **Issue Description (Include Any Relevant Photo or Video)** _____

For Warranty Registration

To register your warranty, please visit www.topens.com

If you have any questions regarding what is covered by the TOPENS warranty, refer to the detailed policy at www.topens.com/pages/topens-limited-warranty.

Email Us: support@topens.com

Table of Contents

Important Safety Information	1
Packing List	4
Installation Overview	5
Specifications	6
Before You Begin	7
Installation	8
Terminal Function of the Control Board	15
Connection of Power Supply	16
Setting of Left / Right Open	17
Program the Remote Control	18
Adjust the Open / Close Limit Position	19
Setting of the Control Board	21
Stall Force Adjustment & Obstruction Test	24
Connection of Accessories	25
TC188 Universal Keypad.....	25
TKP3 Wireless Keypad	27
TC173 Wireless Push Button.....	28
TC196 Tuya WiFi Remote Control	28
TEW3 Vehicle Sensor Exit Wand.....	29
TC175P Wired Keypad	30
HLR01 Homelink Remote Control Kit	30
JD110VY Warning Light	31
TRF3 Reflection Photocell Sensor	31
TC102 Infrared Photocell Sensor	32
ERM12 External Receiver	33
TC148 Waterproof Wall Push Button & TC147 Wall Push Button	33
Maintenance and Replacement Parts	34
Troubleshooting	35

Important Safety Information

Thank you for choosing the TOPENS CK1200 sliding gate opener. When installed correctly and used properly, your opener will offer years of reliable service.

This manual is designed to guide you through the proper installation of your CK1200 sliding gate opener. Please carefully review all instructions before commencing the installation and operation of this automatic gate opener.

Before Installation

- ◆ **GAIN UNDERSTANDING OF THE INSTALLATION PROCESS:** Please read this installation manual or view our online installation video before installing the gate opener.
- ◆ **LOCAL INSTALLATION COMPLIANCE:** Prior to installation, please verify that your planned installation complies with all relevant local building codes and ordinances. Dispose of packaging materials in accordance with local regulations.
- ◆ **SEPARATE PEDESTRIAN ACCESS:** The gate opener is intended for installation only on gates used for vehicles. Pedestrians should use a separate entrance to avoid contact with the moving vehicular gate.

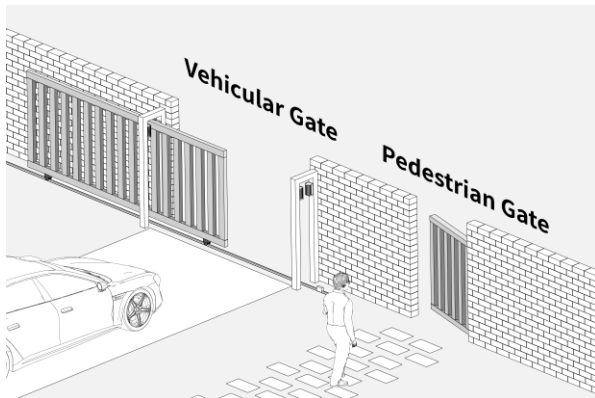

- ◆ **SLIDING GATE PREPARATION:** Ensure that the gate is plumb, level, and slides smoothly in both directions without binding or dragging on the ground. Wheels and guide rollers should rotate easily and be free of dirt or grime. Confirm that the gate track is straight, horizontal, and firmly

affixed. Secure the fence posts in the ground with concrete. Repair or replace all worn or damaged gate hardware prior to installation.

- ◆ **POST OR WALL PROTECTION:** Avoid using the post or wall as a stopping mechanism, either directly or indirectly. This precaution helps protect the post or wall from potential damage due to the impact of the sliding gate.

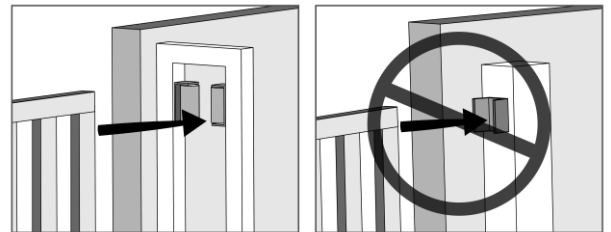

- ◆ **POSITIVE STOPS:** Positive stops must be installed at each end of the gate track to assure that the gate does not exceed its limit of travel and derail while opening or closing fully.

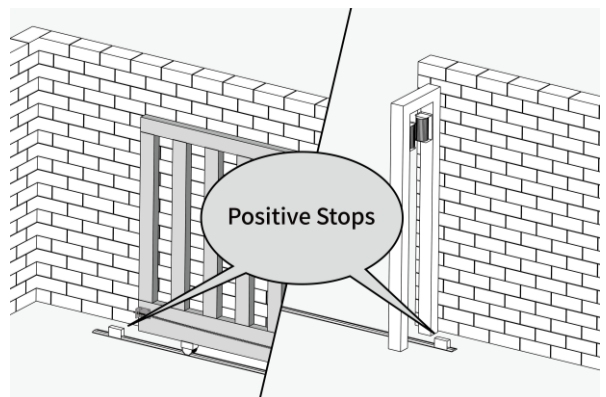

Important Safety Information

During Installation

- ◆ **INSTALLER AND END USER RESPONSIBILITY:** An experienced installer should perform the installation. Improper installation may result in property damage, severe injury or death. The gate opener is only part of the entire gate operating system, and it is the responsibility of the installer and end user to ensure that the total system is safe for its intended use.
- ◆ **DISCONNECT THE POWER SUPPLY:** Ensure that the gate opener is powered off before electrical wire connections or making any adjustments.
- ◆ **INSTALLATION POSITION:** Only install the gate opener on firm, level ground and on the inside of the property or fence line. Ensure there is sufficient clearance between the gate and adjacent structures when opening and closing to minimize the risk of entrapment. Avoid installing it on the outside of the gate where the public has access to it. Avoid installing it in areas prone to flooding or in locations exposed to flammable or explosive fumes.
- ◆ **INSTALL SAFETY SENSOR:** The gate opener is designed to stop or reverse the gate when the gate comes in contact with an obstruction. It is highly recommended to install a photocell sensor in the following situations for safety: if you have children or pets at your property, the gate opener auto close function is set to ON, the gate opener stall force is set to the maximum, a vehicle exit sensor is installed, or other gate

control devices are used.

- ◆ **ENTRAPMENT ATTENTION:** Ensure when the gate is fully open, the end of the sliding gate keeps at least 10cm (4") away from any walls or objects. Exercise caution around moving parts and avoid approaching areas where fingers or hands could get caught. Always keep children, pets and livestock clear of the gate and its path of travel. Never cross the path of a moving gate.

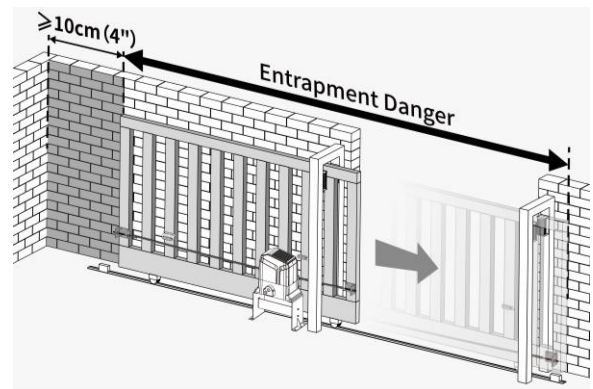

- ◆ **GATE CONTROL ACCESSORIES PLACEMENT:** Gate control accessories intended for user activation must be located at least 1.5 meters (5') away from any moving part of the gate and where the user is prevented from reaching over, under, around or through the gate to operate the controls. Outdoor or easily accessible controls shall have a security feature to prevent unauthorized use.

After Installation

- ◆ **WARNING SIGNS:** Attach the provided warning signs to both sides of the gate in highly visible locations to alert the public about the automatic gate opener system. If your signs are damaged or missing, please reach out to TOPENS Customer Support for replacements.

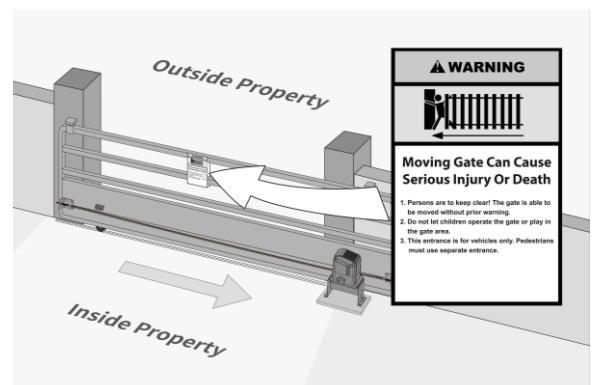

Important Safety Information

- ◆ **AWAY FROM MOVING GATES:** Keep children, pets and livestock away from the gate opener system as moving gates can be dangerous.
- ◆ **SECURE GATE CONTROL ACCESSORIES:** Prevent children from operating or playing with gate controls by keeping remote transmitters, keypads, and push buttons out of their reach. Store in a secure area when not in use.
- ◆ **MAINTENANCE OF GATE OPENER SYSTEM:** Keep the gate properly maintained and its track free of grime and debris. Periodically check that it slides smoothly under manual operation and tighten any loose hardware as needed. Turn off the power to the gate opener before performing any maintenance.
- ◆ **OBSTRUCTION PROTECTION TESTING:** Test the gate opener monthly. The gate must stop or reverse on contact with a rigid object or when an object activates the non-contact sensors. After adjusting the stall force or limit travel, retest the gate opener. Failure to adjust and retest the gate opener properly can increase the risk of injury or death.
- ◆ **POWER DISCONNECTION AND MANUAL OPENING:** Understand how to disconnect the power and manually open the gate. Disconnect the gate opener from the gate only when the gate is not in motion and the gate opener system is turned off.
- ◆ **RECOGNIZE POTENTIAL RISKS IN AUTOMATED GATE SYSTEMS:** Save the installation manual. Make sure everyone who is using or will be around the gate and gate opener are aware of the dangers of automated gate systems. If a replacement manual is needed, you can download a copy from the TOPENS website (www.topens.com).

Note For Warranty

- ◆ **WARRANTY LIMITED TO TARGET MARKET:** The warranty is limited to the target market (Contiguous United States, Canada, UK, and Germany). Customers using the product outside these regions will be responsible for any additional expenses during the warranty replacement process.
- ◆ **GATE OPENER ABUSE:** TOPENS does not cover damage resulting from abuse, such as attempting to operate the gate opener beyond its specified capacity or using it for unintended purposes.
- ◆ **GATE OPENER MISUSE:** TOPENS does not cover damage resulting from misuse, including but not limited to operating the gate opener with incompatible power sources or using it in environments not recommended by TOPENS.
- ◆ **ALTERATIONS OR MODIFICATIONS:** Alterations or modifications made to the gate opener without prior consultation with TOPENS will also invalidate warranty coverage.
- ◆ **NON-COMPLIANCE WITH INSTRUCTIONS:** Failure to follow the installation instructions, including but not limited to improper installation, maintenance will void the warranty.
- ◆ **THIRD PARTY ACCESSORIES:** TOPENS does not cover damage caused by third party accessories, except those specifically recommended by TOPENS Customer Support. It is important to use only compatible accessories to ensure compatibility and prevent damage to the gate opener.
- ◆ **CONTACT TOPENS SUPPORT:** Please ensure that the gate opener is installed, operated, and maintained in accordance with the guidelines outlined in the installation manual to avoid voiding the warranty. If you have any questions regarding proper usage or need assistance with compatible accessories, please contact TOPENS Customer Support for guidance.
- ◆ **DETAILED WARRANTY POLICY:** If you have any questions regarding what is covered by the TOPENS warranty, refer to the policy at www.topens.com/pages/topens-limited-warranty.

Packing List

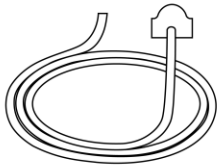

Power Cord

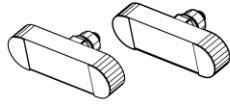

Magnet Assembly

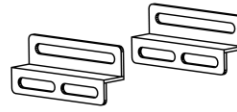

Magnet Bracket

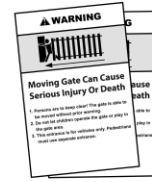

Warning Sign

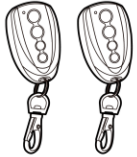

Remote Control

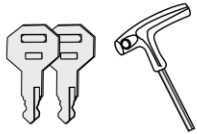

Key & T-handle Key

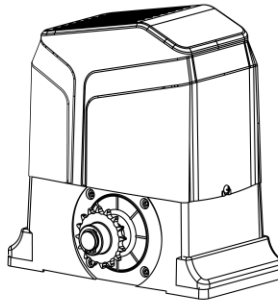

Gate Opener

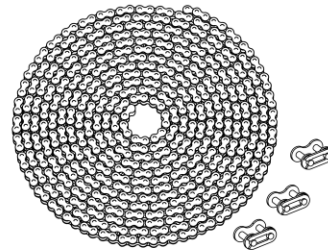

Roller Chain 6m (20 feet)
& Master Link

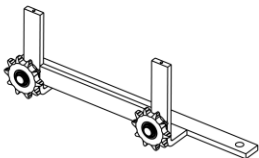

Idler Wheel Assembly (1)

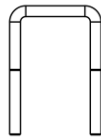

Square "U" Bolt (4)

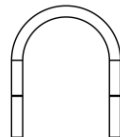

Round "U" Bolt (4)



M6x12 Socket Head Screw (4)



M6 Self-Locking Nut (4)

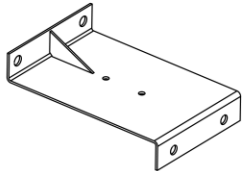

Side Bracket (2)

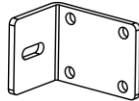

"L" Bracket (2)



M4x8 Pan Head Screw (2)



M10x30 Hex Bolt (4)

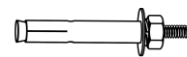

Expansion Bolt (4)

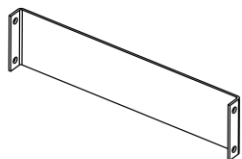

Middle Beam (1)



Chain Bolt (2)



Φ8 Plain Washer (20)



Φ10 Plain Washer (8)

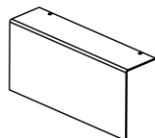

Wheel Cover (1)

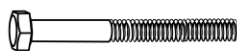

M8x70 Hex Bolt (4)



Φ8 Lock Washer (20)



Φ10 Lock Washer (8)

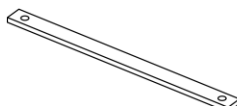

Upper Beam (1)



M8 Hex Nut (20)



M10 Hex Nut (4)

Supplementary Chain

(If the chain is insufficient, additional chain can be purchased separately at www.topens.com.)

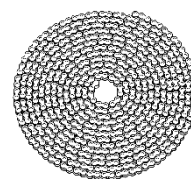

LT08B 20 Feet
Roller Chain

Installation Overview

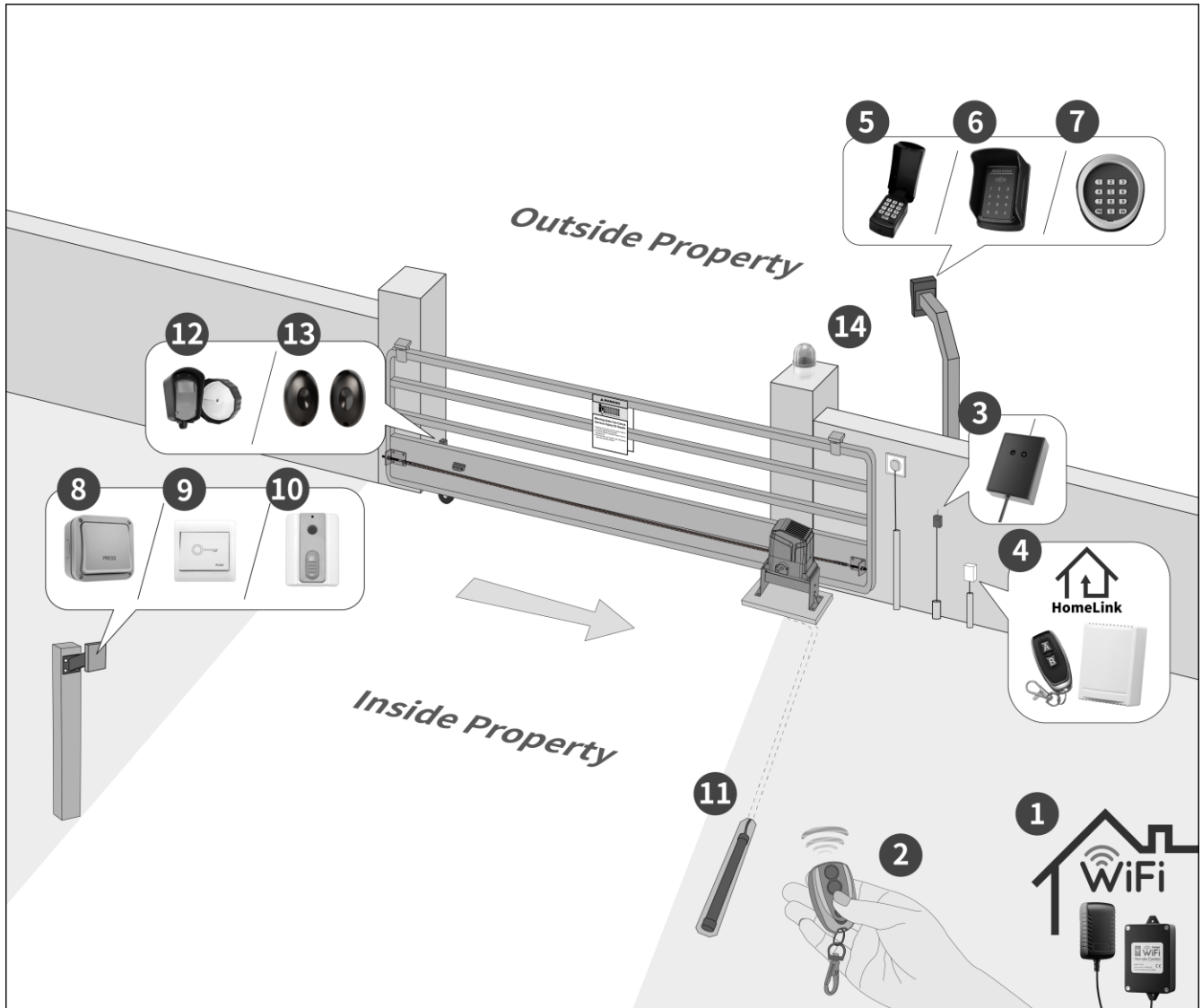

Various TOPENS Accessories for Your Gate Opener System

1 TC196 WiFi Remote Control	8 TC148 Waterproof Wall Push Button
2 M12 Remote Control	9 TC147 Wall Push Button
3 ERM12 External Receiver	10 TC173 Wireless Push Button
4 HLR01 Homelink Remote Control Kit	11 TEW3 Vehicle Sensor Exit Wand
5 TC188 Universal Keypad	12 TRF3 Reflection Photocell Sensor
6 TC175P Wired Keypad	13 TC102 Infrared Photocell Sensor
7 TKP3 Wireless Keypad	14 JD110VY Warning Light

* Available on the TOPENS website (www.topens.com) and Amazon.

Specifications

Product Model	CK1200
Power Input	110-120VAC/60Hz
Motor Voltage	120VAC
Motor Power	550W (3/4 HP)
Gate Moving Speed	20 cm/s (8 in/s)
Max Gate Weight	1500kg (3400lbs)
Max Gate Length	12m (40ft.)
Working Temperature	-20°C ~ +50°C (0°F to 120°F)
Protection Class	IP44 Waterproof
Sound Level	< 50 dB

Overall Dimensions

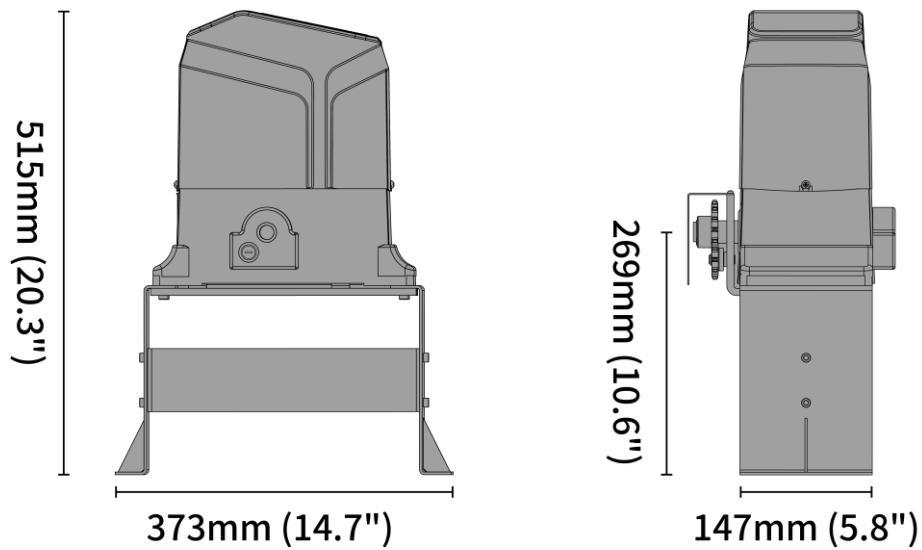

Before You Begin

Check the Gate

- ◆ Ensure that the gate is plumb, level, and slides smoothly in both directions without binding or dragging on the ground.
- ◆ Confirm that the gate track is straight, horizontal, and firmly affixed, with positive stops installed at each end.
- ◆ Make sure the gate wheels and guide rollers rotate freely and are clean of dirt or grime.
- ◆ Ensure that the fence posts are securely set in concrete.
- ◆ Repair or replace all worn or damaged gate hardware before installation.

Tools Needed

- ◆ Power Drill
- ◆ Tape Measure
- ◆ Open End Wrenches - 14# & 17# or Adjustable Wrenches
- ◆ Wire Strippers
- ◆ Phillips Screwdriver
- ◆ Slotted Screwdriver

Items Not Included but May Needed

- ◆ **PVC Conduit:** Required to protect the cable connecting TC102 infrared photocell sensor to the control board.
- ◆ **Connection Cable:** Connection cable may be required for installing wired accessories. Refer to the Connection of Accessories section in this manual to purchase the correct cable.
- ◆ **Weatherproof Cover:** Use a weatherproof cover to protect the electrical outlet if it is located outdoors.
- ◆ **Surge Protector:** A surge protector with a rated current of 10A is recommended to use with the power cord.

Install Photocell Sensor

- ◆ It is highly recommended to install a photocell sensor in the following situations for safety: if you have children or pets at your property, the gate opener auto close function is set to ON, the gate opener stall force is set to the maximum, a vehicle exit sensor is installed, or other gate control devices are used.

Installation

CAUTION

- ◆ Ensure that the opener is installed in a level and parallel position and is securely fastened.
- ◆ Improper installation may result in property damage, severe injury, and / or death.

STEP 1

Assemble the Base Plate

- ◆ Assemble the middle beam and side brackets as shown, securing them with M6x12 Socket Head Screws and M6 Self-Locking Nuts.

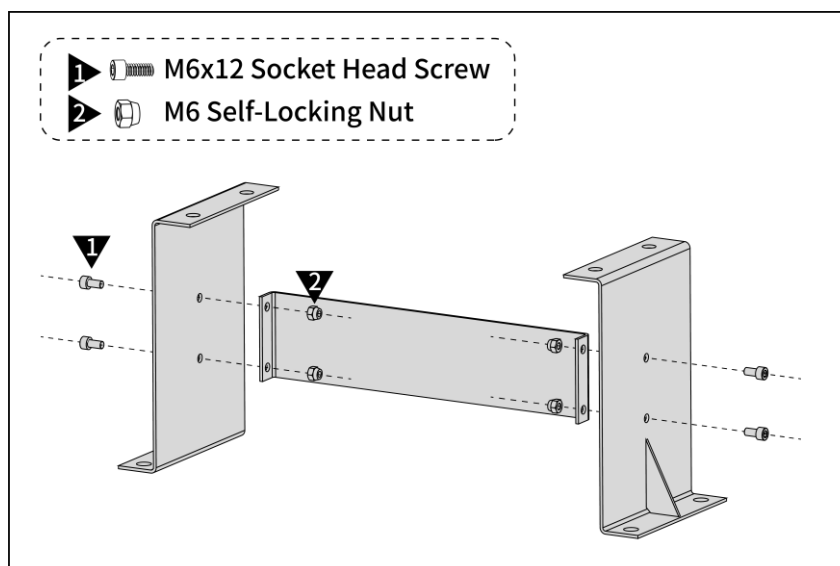

STEP 2

Install the Motor on the Base Plate

- ◆ Unscrew the two cover screws located on each side of the motor casing to remove the casing.
- ◆ Unscrew the four screws on the two side covers located on each side of the motor.
- ◆ Place the motor on the base plate, fasten the motor along with the idler wheel assembly and upper beam to the base plate with M10x40 Hex Bolts, ϕ 10 Lock Washers, and ϕ 10 Plain Washers.
- ◆ Adjust the motor's position to align its drive sprocket with the two idler wheels.
- ◆ Securely tighten all nuts and bolts on the base plate.

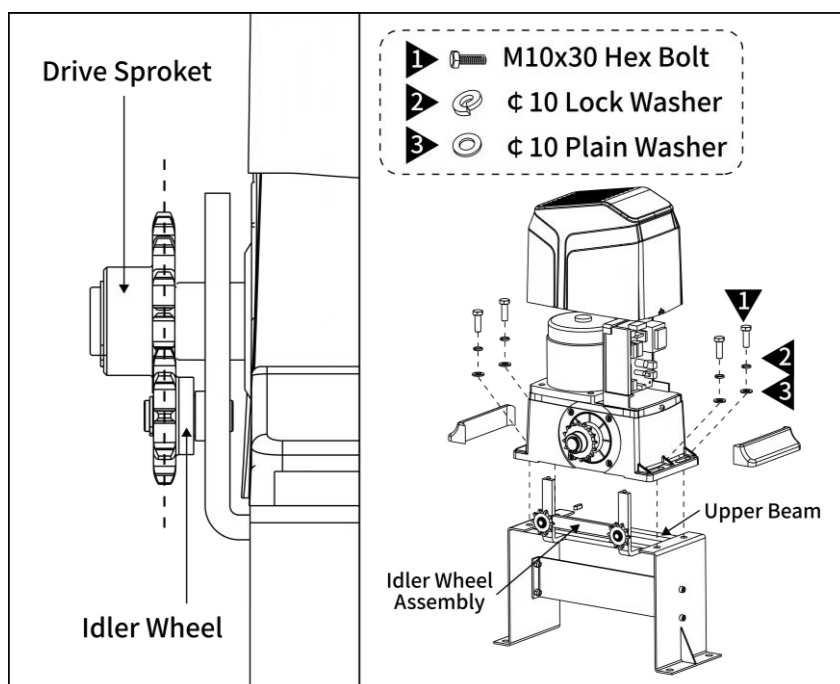

Installation

STEP 3

Lay out the Concrete Pad

- ◆ Dig a hole for a concrete pad near the front roller of the gate. The dimensions should be approximately 600 x 320 x 350mm (24" x 13" x 14").
- ◆ Install the electrical conduit.
- ◆ Pour the concrete pad.
- ◆ Ensure that the pad surface is perfectly level and parallel to the driveway.
- ◆ Increase the pad height if necessary to protect the system from flooding, heavy snow, etc.

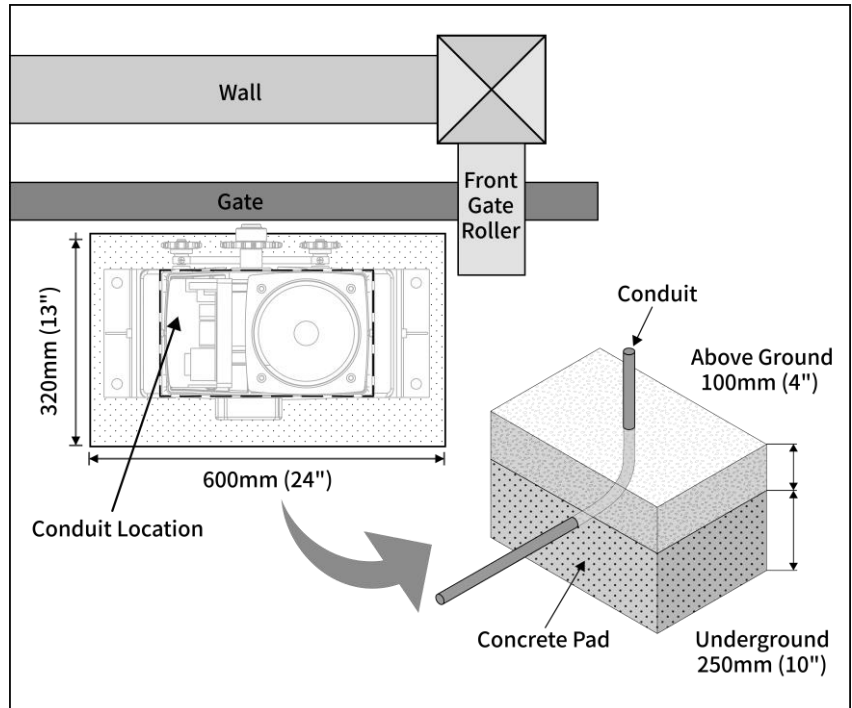

Installation

STEP 4

Determine the Position of the Opener

- ◆ Position the opener on the concrete pad.
- ◆ Attach the "L" bracket to the left side of the gate. Adjust the opener's position until the teeth of the drive sprocket are vertically aligned with the hole in the "L" bracket.
- ◆ Push the gate to the right and attach the "L" bracket to the right side of the gate. Adjust the opener's position to align the teeth of the drive sprocket with the hole in the "L" bracket.
- ◆ Temporarily place the wheel cover on the idler wheel assembly to ensure that there is at least 13mm (0.5") of clearance between the wheel cover and the gate.
- ◆ Mark the locations for the four expansion bolts based on the mounting holes on the base plate. Drill the holes with a 14mm (0.55") masonry bit.
- ◆ Firmly secure the base plate to the concrete pad with the expansion bolts.

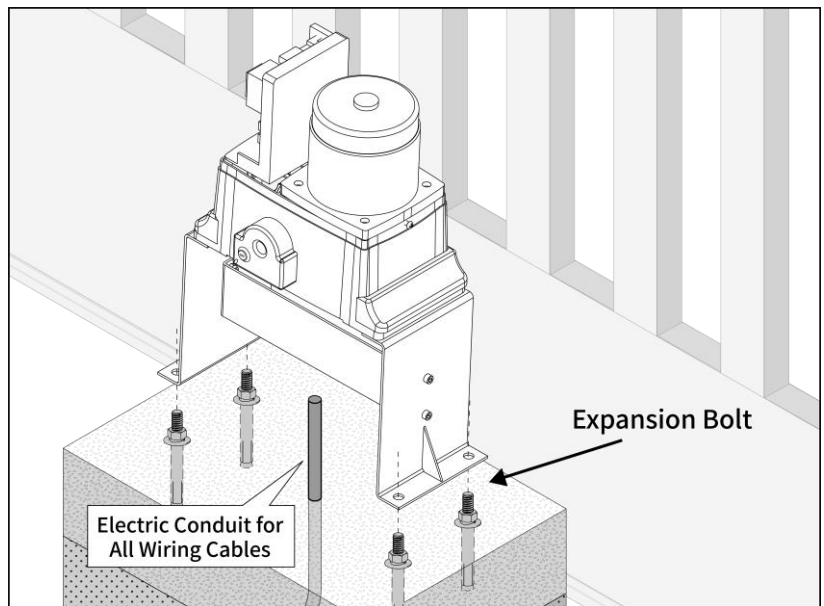
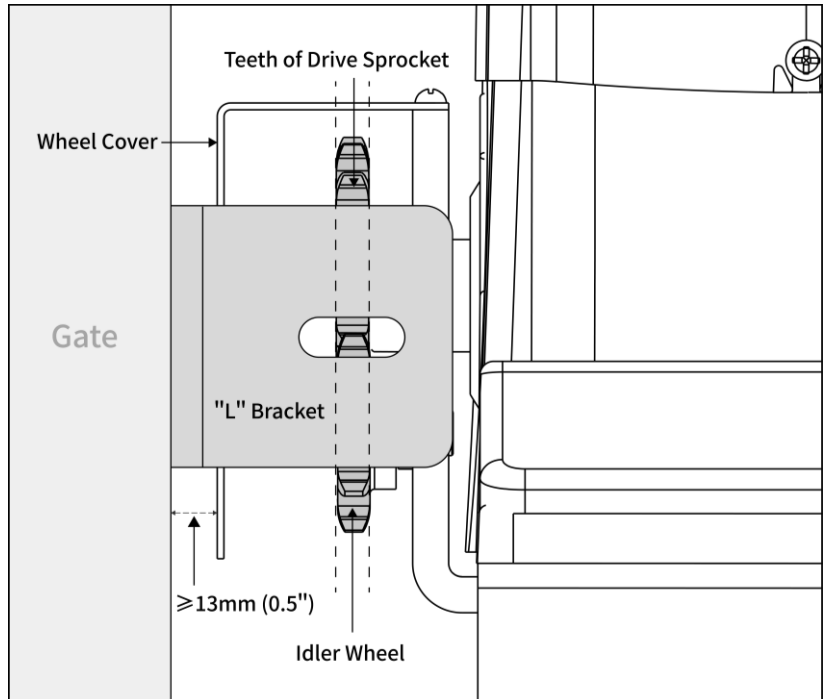

STEP 5

Disengage the Clutch

- ◆ Insert and turn the key clockwise 45° to slide the lock cover, revealing the key slot. Then, insert the T-handle key into the key slot and turn it counterclockwise 135° to disengage the clutch between the gear shaft and the motor.
- ◆ The gate opener is now in manual mode, allowing you to open the gate by hand freely.

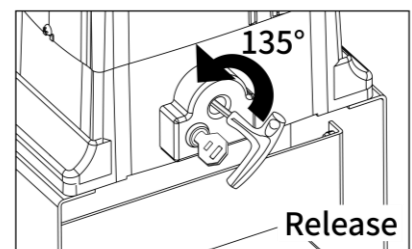
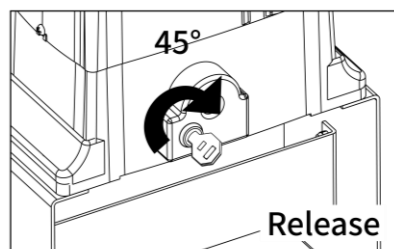

Installation

STEP 6

Install the Chain Brackets

- ◆ Install the "L" bracket with the "U" bolt (square or round), ϕ 8 Plain Washers, ϕ 8 Lock Washers, and M8 Hex Nuts at or near each end of the inside gate (opener side).
- ◆ Ensure that the top of the idler wheel is aligned with the hole in each side of the "L" brackets.
- ◆ If neither the square nor the round "U" bolts fit the gate frame, use appropriate bolts to attach the "L" brackets to the gate frame.
- ◆ Attach the chain bolt to each side of the "L" bracket with ϕ 10 Plain Washers, ϕ 10 Lock Washers, and M10 Hex Nuts.

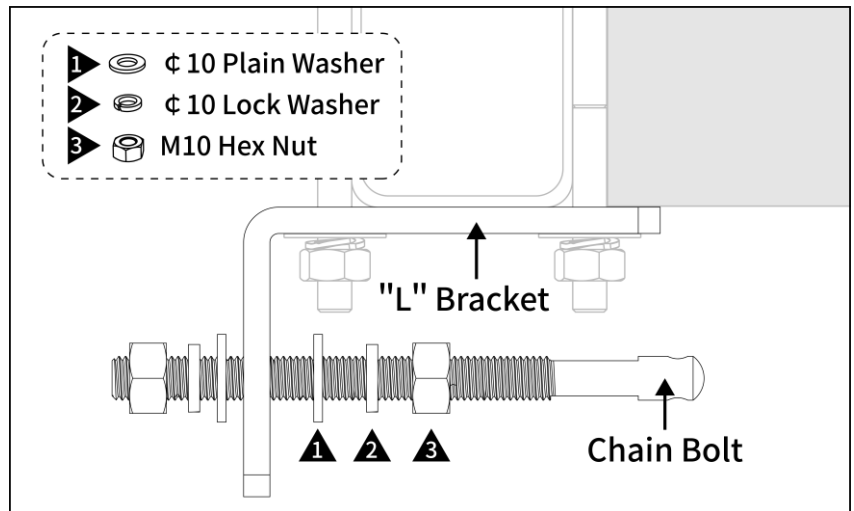
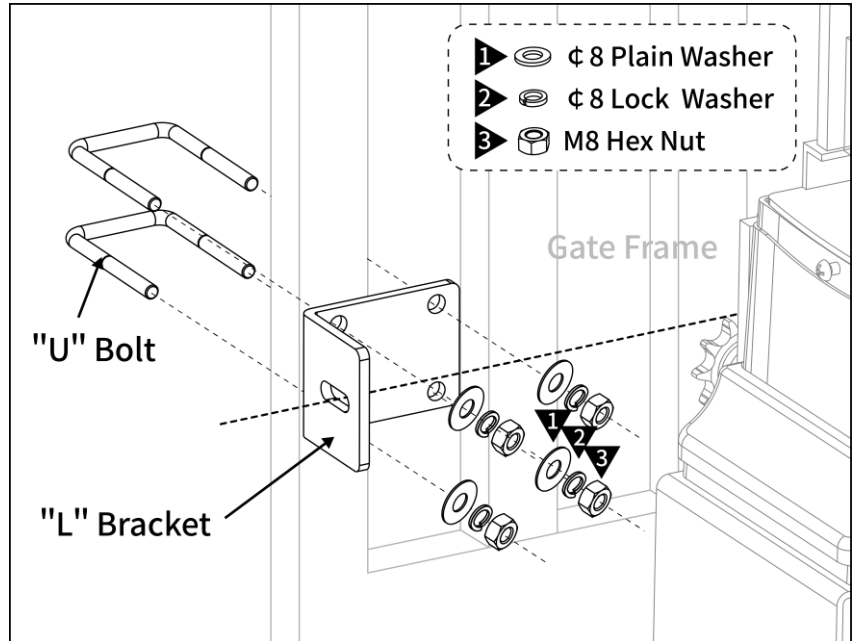

CAUTION: Once the positions of the opener and chain brackets are determined, double-check the safety distance between them to ensure that they do not collide, even if the gate wheel accidentally hits the positive stop. Reinstall the positive stop if necessary.

- ⚠ Keep at least a 80mm (3") distance between the opener and the chain bracket, even if the gate wheel accidentally hits the Positive Stop.

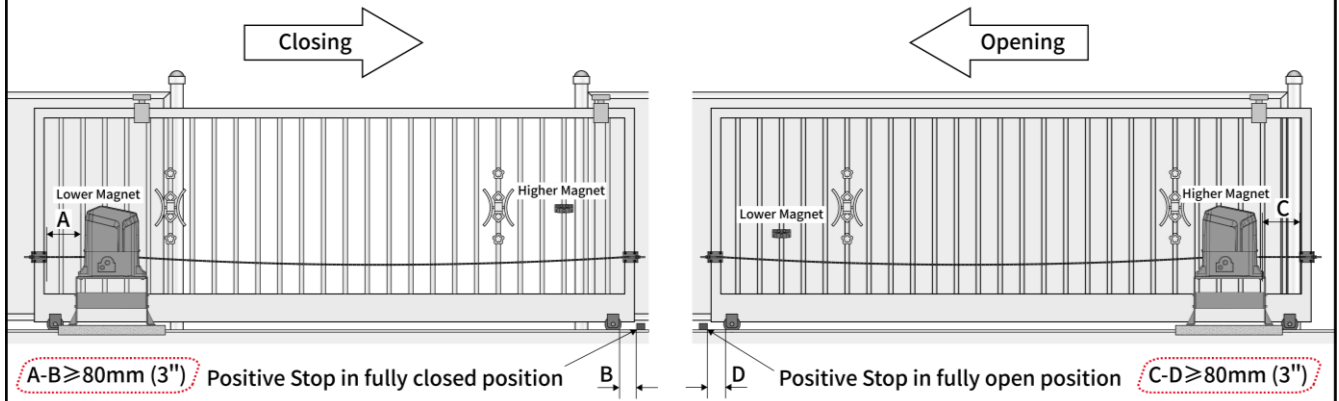

Installation

STEP 7

Fit the Chain

- ◆ Connect one end of the chain to one side of chain bolt with the master link.
- ◆ Route the chain through the opener.
- ◆ Cut any excess chain and connect the end to the other side of the chain bolt with the master link.
- ◆ Set the appropriate chain tension by adjusting the chain bolts at both ends. The chain should be neither too tight nor too slack.
- ◆ Install the wheel cover to the idler wheel assembly with the included M4x8 Pan Head Screws.
- ◆ Manually open and close the gate to ensure that it moves smoothly with the chain installed.

NOTE: Applying anti-rust oil to the chain will help prevent rust.

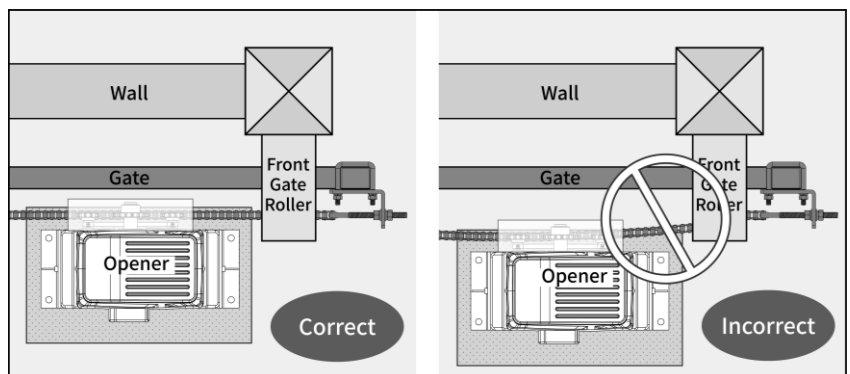
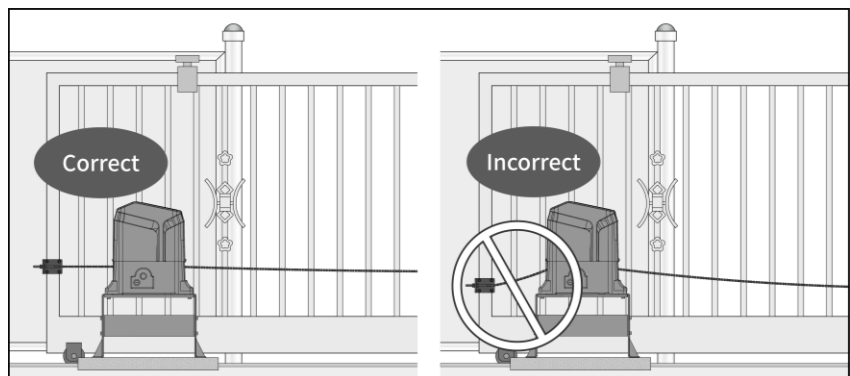
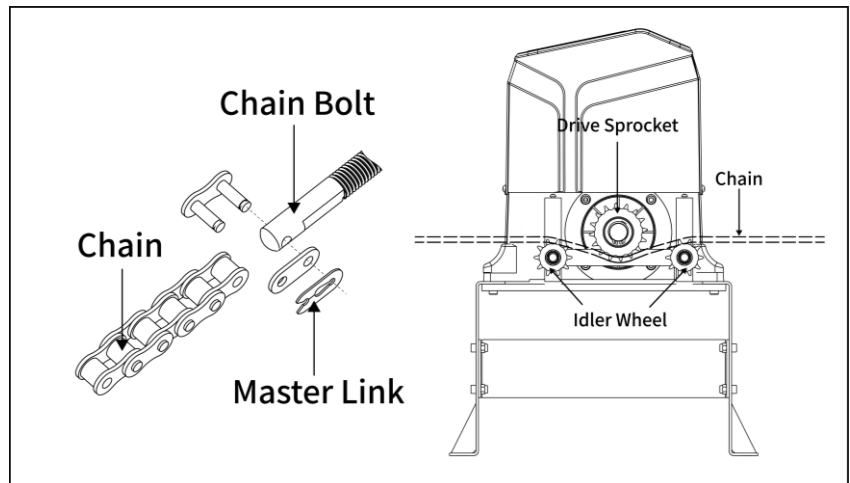

Installation

STEP 8

Install the Magnets

- ◆ Attach the magnets to the magnet brackets.
- ◆ From the inside view of the property, install the magnet bracket **lower** on the **left** side and **higher** on the **right** side. Ignore the N and S labels on the magnets; they can be mounted on either side.
- ◆ Manually close the gate completely and install the appropriate magnet bracket so that the opener stops at the desired closed position when the magnet senses the limit switch. Similarly, fully open the gate and install the appropriate magnet bracket so that the opener stops at the desired open position when the magnet senses the limit switch. Leave some space at both ends of the gate for buffering.
- ◆ Adjust the lower magnet to ensure that its center is aligned with the DOWN LIMIT line on the limit switch box. Adjust the higher magnet to align its center with the UP LIMIT line.
- ◆ Secure the magnet brackets to the gate with M8x70 Hex Bolts, ϕ 8 Plain Washers, ϕ 8 Lock Washers, and M8 Hex Nuts. Double-check that the magnets are 20-30mm (0.8-1.2") away from the limit switch box.

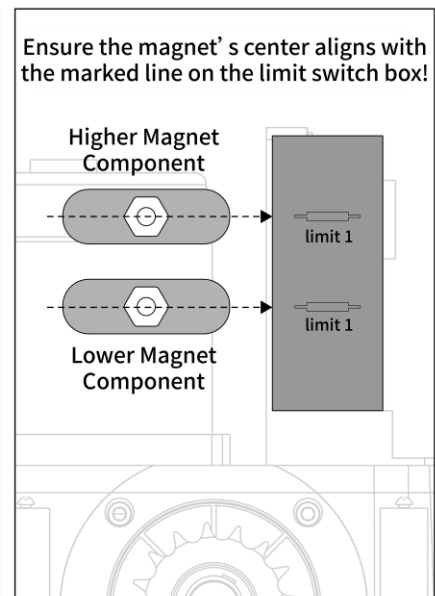
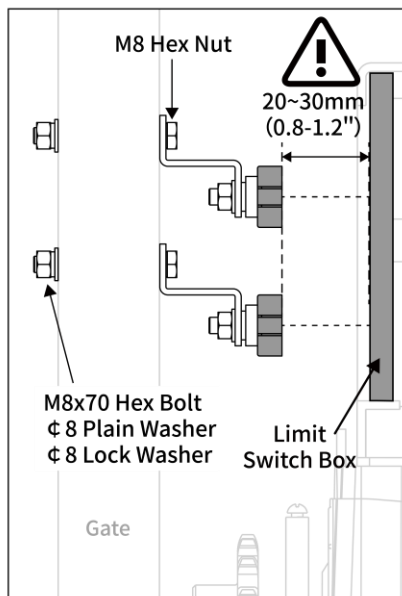
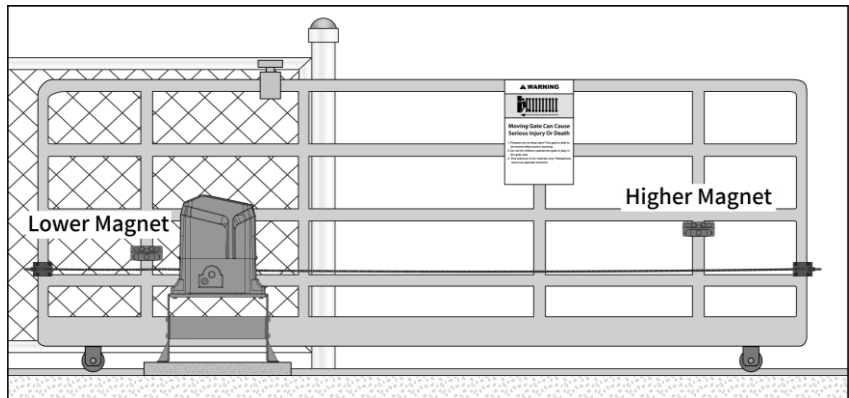
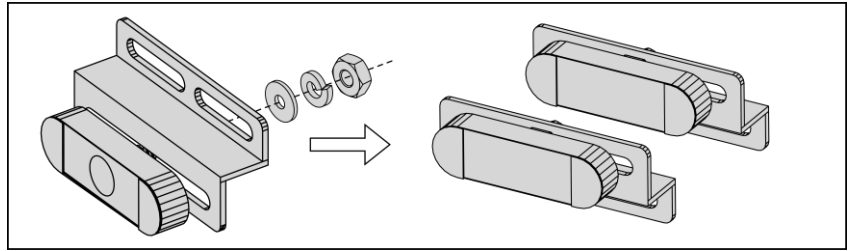

NOTES:

- ◆ Precise installation of the magnets ensures accurate control of the gate's opening and closing positions. You can adjust the open / close limit position according to your needs.
- ◆ Improper installation of the magnets may cause the gate to crash into the end barrier, posing a significant safety risk! It is highly recommended to watch our step-by-step installation video on YouTube for guidance.

Installation

STEP 9

Engage the Clutch

- ◆ Insert the T-handle key into the key slot, turn it clockwise 135° , and then remove it.
- ◆ Turn the key counterclockwise 45° to cover the key slot, then remove it.

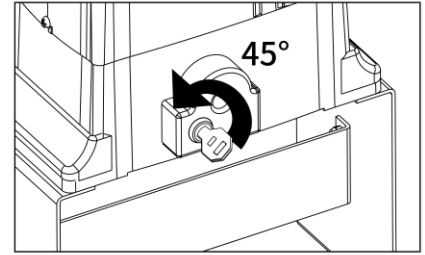
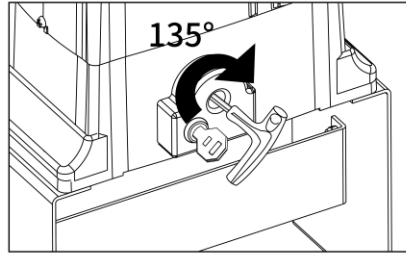

Terminal Function of the Control Board

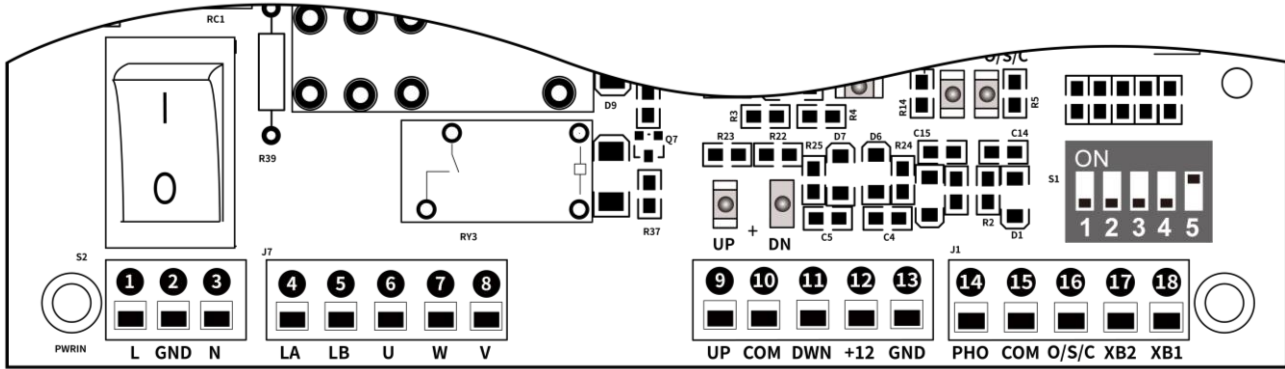

Terminal	Function
① “L” ② “GND” ③ “N”	Input terminals for AC power, connected to the live, earth and neutral wires of the power cord respectively.
④ “LA” ⑤ “LB”	Output terminals for a warning light, directly connected to the warning light, providing the same voltage as the mains supply during gate operation, causing the warning light to flash. Ensure that the warning light has a rated voltage matching the motor voltage and a rated current of less than 1A.
⑥ “U” ⑦ “W” ⑧ “V”	Input terminals for the motor and built-in start capacitor, the terminals are pre-connected at the factory.
⑨ “UP” ⑩ “COM” ⑪ “DWN”	Input terminals for a normally open limit switch, connected to the red, black and yellow wires of the limit switch, respectively.
⑫ “+12” ⑬ “GND”	Auxiliary output terminals, providing 12VDC power to accessories (rated output less than 100mA).
⑭ “PHO” ⑮ “COM”	Receive signal input from a photocell sensor, operating on a normally open (NO) input basis, connected to “NO” and “COM” terminals of the sensor respectively.
⑮ “COM” ⑯ “O/S/C”	Control gate operation through a normally open dry contact signal input, commonly connected to push button, wired keypad, and external receiver for cyclic gate operation (open/stop/close/stop).
⑰ “XB2” ⑱ “XB1”	Accept the signal input of the gate opening, can only be connected to the normally open output of the TOPENS TEW3 vehicle sensor exit wand. The signal input will only be accepted when the adapter board of the TOPENS TEW3 vehicle sensor exit wand is properly connected to the control board.

NOTE: For terminal wiring, remove the terminal from the control board and unscrew the terminal screws using a screwdriver. Insert the wire into the terminal, tighten the screws to secure the wire, and then reattach the terminal to the control board.

Connection of Power Supply

WARNING

- ◆ A professional electrician is required for wire connection to avoid the risk of injury, electric shock, or death. NEVER connect the gate opener to an electrical outlet before all the installations have been done.
- ◆ It is recommended to use a surge protector with a rated current of 10A with the power cord. Protect the electrical outlet with a weatherproof cover if it is located outdoors.

The gate opener is powered by AC electricity ONLY.

- ◆ The specification of the power cord is $3C \times 0.75\text{mm}^2$ (18AWG).
- ◆ Connect the live wire (black) and neutral wire (white) of the power cord to control board terminal ① “L” and terminal ③ “N”, respectively. And connect the earth wire (green) to terminal ② “GND” .
- ◆ Plug the power cord into an electrical outlet.

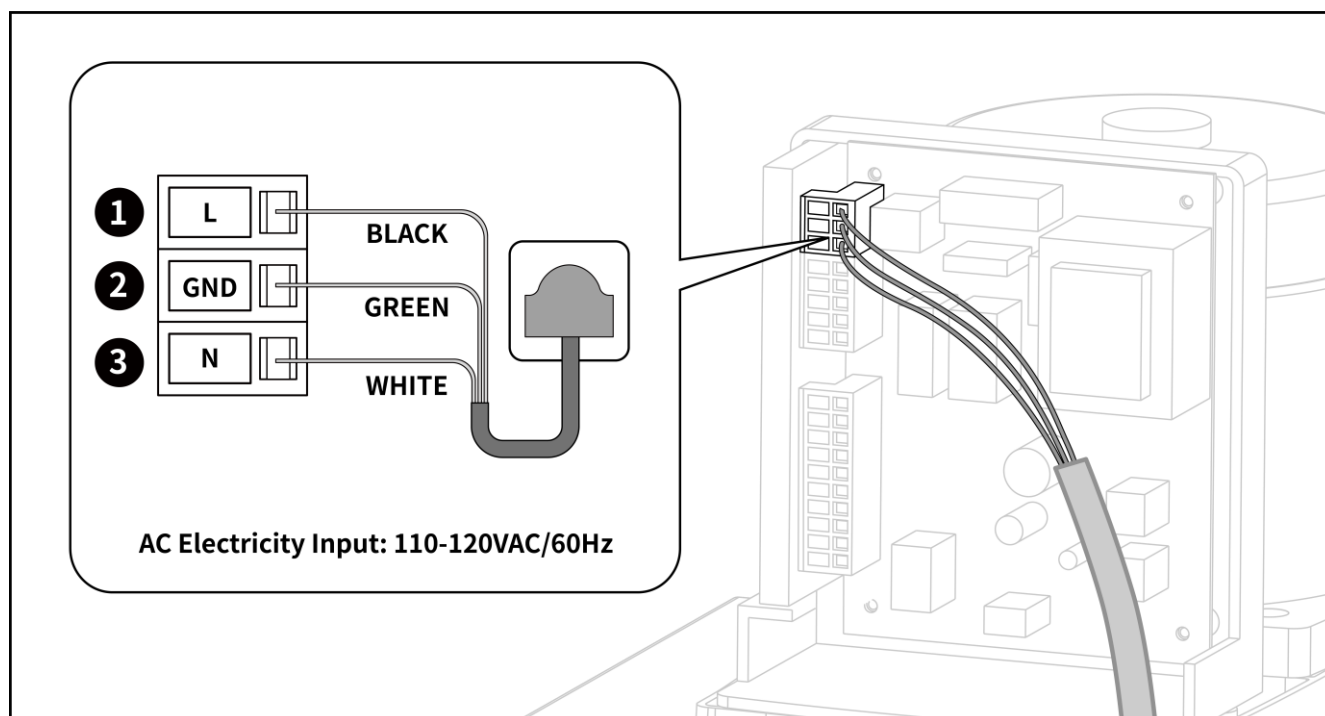

Setting of Left / Right Open

WARNING

- ◆ Before operating your gate opener, ensure that the Left / Right Open setting on the control board matches the opening direction of the gate.
- ◆ If the opener is installed on the left side of the driveway and the gate opens to left, set the opener to **Left Open**. If the opener is installed on the right side of the driveway and the gate opens to right, set the opener to **Right Open**.
- ◆ Please refer to the DIP Switch Settings section for detailed instructions.

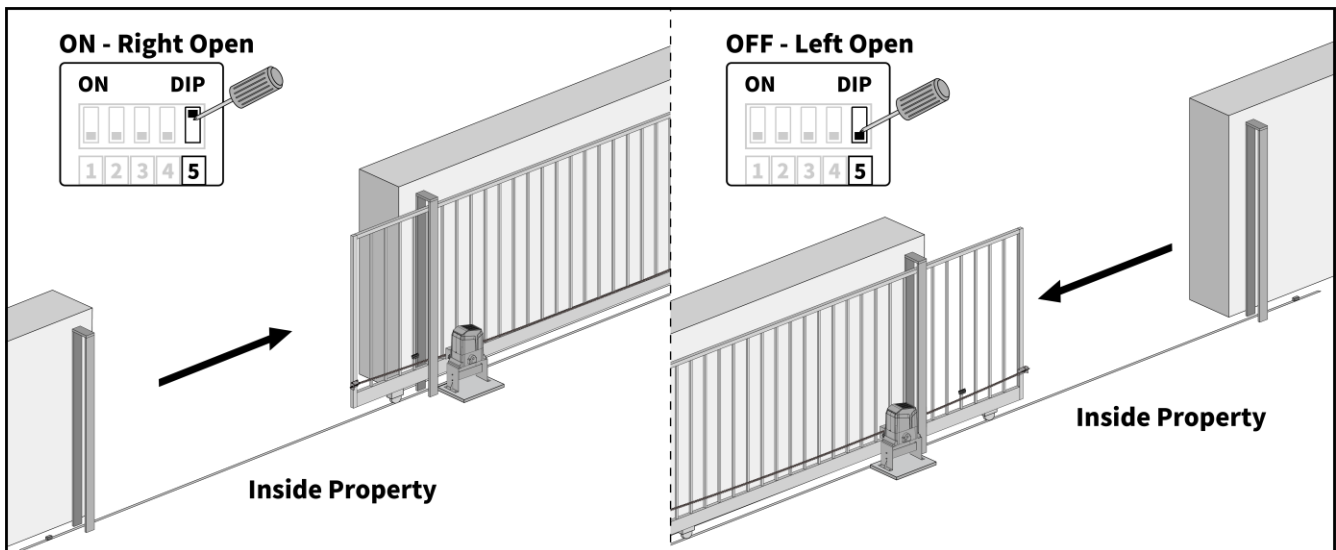

Program the Remote Control

NOTES

- ◆ Keep the gate movement area free of obstructions, and ensure children, pets and livestock stay away from the gate opener system while the gate is in motion.
- ◆ If you lose any remote control, please erase and reprogram all remaining remote controls for safety.

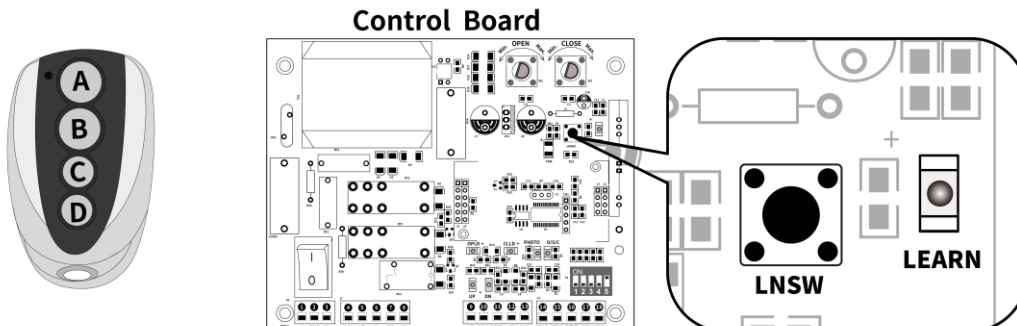

Function of the Remote Control Button

- ◆ Each remote has four buttons, from top to bottom are separately A, B, C and D.
- ◆ For the sliding gate opener, button A is used to be programmed with the gate opener for standard operation. Once button A is programmed, button B automatically activates midway mode to partially open the gate for quick passage. If the midway mode function is disabled, button B functions the same as button A. Buttons C and D can be programmed separately to operate additional sliding gate openers by adding extra ERM12 External Receivers (available on the TOPENS website www.topens.com) to each control board, allowing for standard operation without midway mode.
- ◆ Each press of the programmed button A cycles the gate through open, stop, close, stop, and open. With the ERM12 external receiver, the programmed buttons C and D can also control the gate with the same open, stop, close, stop, and open cycle.

How to Program the Remote Control

The remote control MUST be programmed to the gate opener before use. The remote controls that come with the gate opener are preprogrammed.

If you purchase additional remote controls, or if the programmed remotes are not working, repeat the programming steps below for each remote control.

Enter Programming Mode

- ◆ Press and release the LNSW button on the control board. The LEARN LED will turn on, indicating that the gate opener is now in programming mode.

Program the Remote Control

- ◆ Press the remote control button you want to program once, then press it again after the LED on the remote turns off.
- ◆ The LEARN LED will flash for 3 seconds and then turn off, indicating successful programming.

Additional Remote Controls

- ◆ The gate opener can pair Max. 8 M12 remote controls on its own, and up to 250 with the ERM12 External Receiver (sold separately on the TOPENS website www.topens.com).

How to Erase All Programmed Remote Controls

- ◆ Press and hold the LNSW button until the LEARN LED turns from ON to OFF. Now all programmed remote controls have been erased.

Adjust the Open / Close Limit Position

WARNING

- ◆ Before making any adjustments, disengage the clutch of the gate opener to prevent the gate from moving unexpectedly.
- ◆ Ensure that the lower magnet bracket is always positioned on the left side and the higher magnet bracket on the right side when viewed from inside the property. Leave some space at both ends of the gate for proper buffering.

For Left Open Gate

Adjusting the Open Limit Position

- ◆ Use the remote control to open the gate. If the gate stops halfway and fails to get to the desired open position, disengage the clutch. Use an adjustable wrench to loosen the screw of the **higher (right)** magnet. Gently slide the magnet slightly to the right, then tighten the screw firmly. Engage the clutch and test the gate.
- ◆ If the gate opens over the desired open position, adjust the **higher** magnet slightly to the left. Tighten the screw securely.
- ◆ Repeat the above steps until the gate automatically stops at the desired open position.

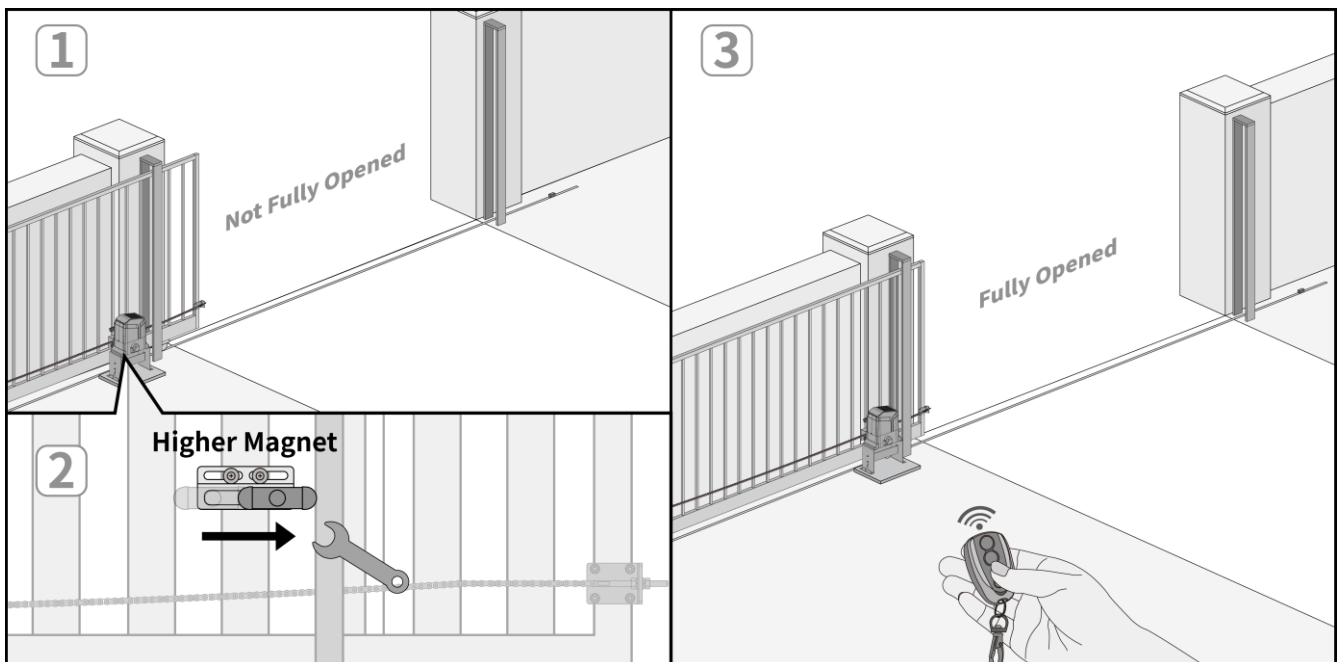

Adjusting the Close Limit Position

- ◆ Use the remote control to close the gate. If the gate stops halfway and fails to get to the desired closed position, disengage the clutch. Use an adjustable wrench to loosen the screw of the **lower (left)** magnet. Carefully move the magnet slightly to the left, then tighten the screw securely. Engage the clutch and test the gate.
- ◆ If the gate closes over the desired closed position, adjust the **lower** magnet slightly to the right. Tighten the screw securely.
- ◆ Repeat the above steps until the gate automatically stops at the desired closed position.

Adjust the Open / Close Limit Position

For Right Open Gate

Adjusting the Open Limit Position

- ◆ Use the remote control to open the gate. If the gate stops halfway and fails to get to the desired open position, disengage the clutch. Use an adjustable wrench to loosen the screw of the **lower (left)** magnet. Gently slide the magnet slightly to the left, then tighten the screw firmly. Engage the clutch and test the gate.
- ◆ If the gate opens over the desired open position, adjust the **lower** magnet slightly to the right. Tighten the screw securely.
- ◆ Repeat the above steps until the gate automatically stops at the desired open position.

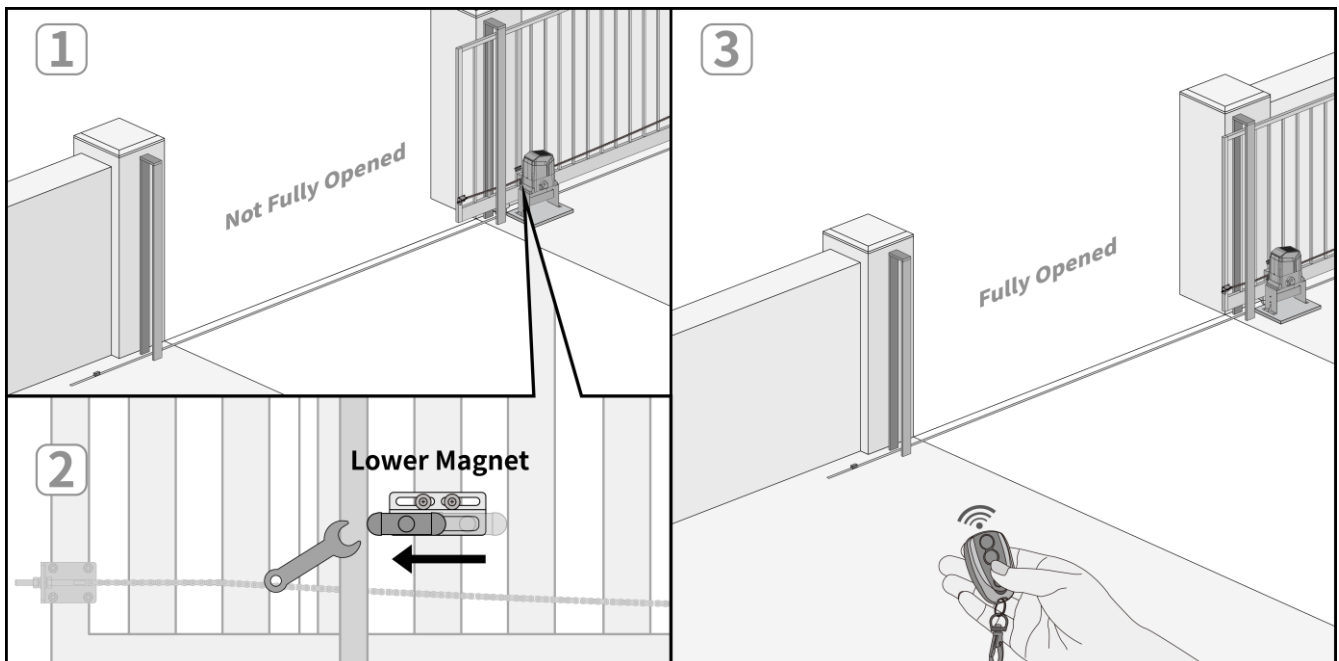

Adjusting the Close Limit Position

- ◆ Use the remote control to close the gate. If the gate stops halfway and fails to get to the desired closed position, disengage the clutch. Use an adjustable wrench to loosen the screw of the **higher (right)** magnet. Carefully move the magnet slightly to the right, then tighten the screw securely. Engage the clutch and test the gate.
- ◆ If the gate closes over the desired closed position, adjust the **higher** magnet slightly to the left. Tighten the screw securely.
- ◆ Repeat the above steps until the gate automatically stops at the desired closed position.

Setting of the Control Board

WARNING

- ◆ Ensure that the gate opener is powered off when making any adjustments.
- ◆ Keep away from the gate while setting up the gate opener system to avoid unexpected gate movement.
- ◆ Carefully adjust the DIP switches to prevent the risk of damaging the gate opener and causing injury or death.
- ◆ Always seek assistance from a professional technician or electrician if you have any questions.

DIP Switch Settings

There are five DIP Switches located on the main control board (as shown) that must be positioned correctly for your particular installation.

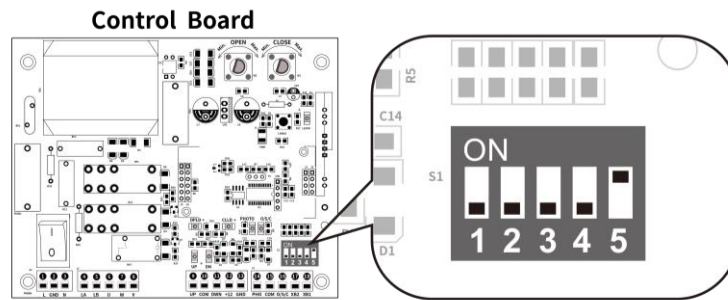

DIP Switch #1 - #2: Set the Running Time of the Motor in Midway Mode

The midway mode allows the gate to partially open for quick passage.

DIP Switch #	ON Position	OFF Position
1	2 Seconds	0 Second (Factory Default)
2	4 Seconds	0 Second (Factory Default)

IMPORTANT NOTES:

- ◆ The midway mode function is disabled when both DIP switches are set to OFF by default.
- ◆ The running time of the motor in midway mode is DIP Switch #1 + DIP Switch #2.
- ◆ Press button B on the remote control to activate the midway mode when the gate is in fully closed position.

Midway Mode:

1. Gate is in the fully closed position.
2. DIP Switch #1 and DIP Switch #2 are set to ON.
3. Press button B on the remote control to open the gate.

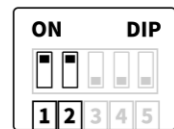

Gate will open for 6 seconds and then stop automatically.

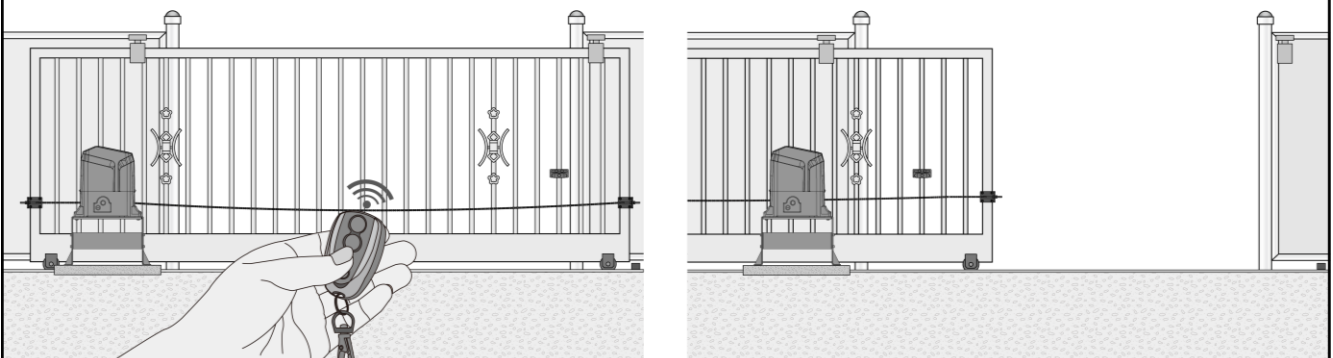

Setting of the Control Board

DIP Switch #3- #4: Set the Auto Close Time of the Gate Opener

The auto close function allows the gate to automatically close after a set period.

DIP Switch #	ON Position	OFF Position
3	30 Seconds	0 Second (Factory Default)
4	60 Seconds	0 Second (Factory Default)

IMPORTANT NOTES:

- ◆ The auto close function is disabled when both DIP switches are set to OFF by default.
- ◆ The auto close time of the gate opener is DIP Switch #3 + DIP Switch #4.
- ◆ The auto close function should be enabled if a vehicle sensor exit wand is installed.
- ◆ When the auto close function is enabled, the photocell sensor is highly recommended to be installed with the gate opener for safety.

DIP Switch #5: Set Left / Right Open

ON – Right open

OFF – Left open

The factory default setting is **ON**.

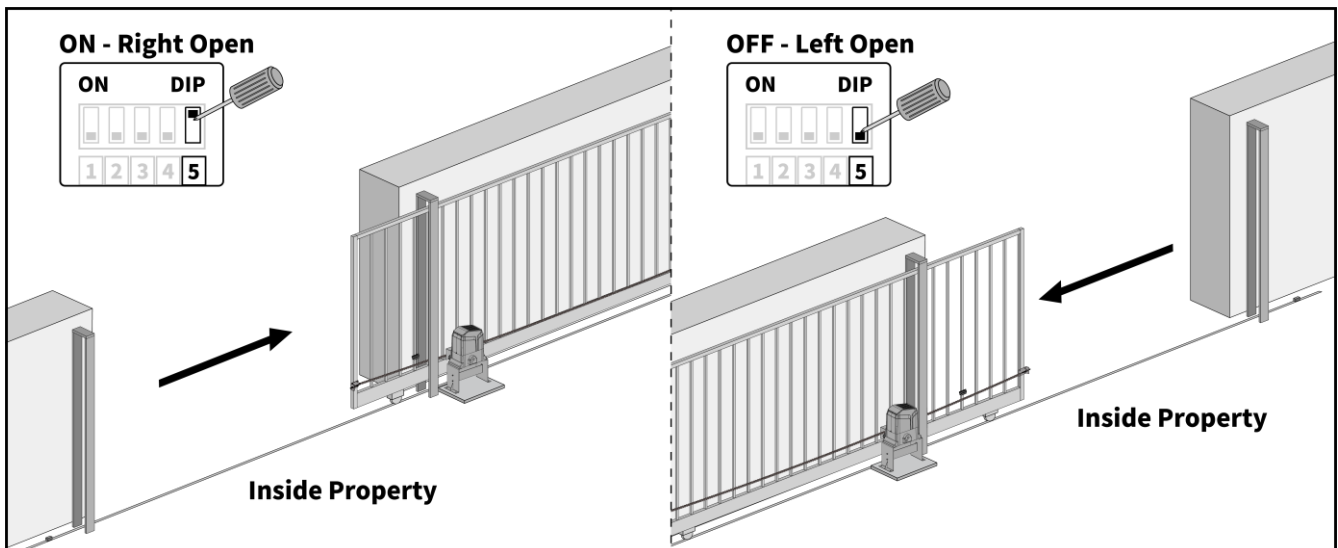

Setting of the Control Board

Potentiometer Settings

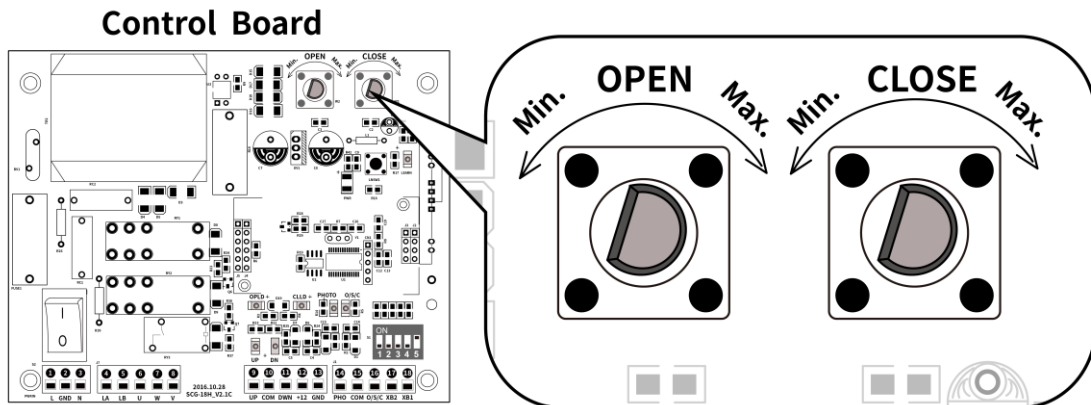

OPEN Potentiometer: Adjust the Open Stall Force of the Gate Opener

CLOSE Potentiometer: Adjust the Close Stall Force of the Gate Opener

- ◆ Turn the potentiometer clockwise to increase the stall force, and counterclockwise to decrease it.
- ◆ Stall force regulates the gate's sensitivity to obstacles during operation. A higher stall force setting decreases sensitivity, making the gate less likely to detect objects. Conversely, a lower stall force setting increases sensitivity, causing the gate to stop or reverse more readily when encountering even minor obstructions.

Stall Force Adjustment & Obstruction Test

Fine Tune the Stall Force

This force should be high enough to ensure the gate reaches both open and close limits without reversing unnecessarily or causing frequent interruptions, but low enough to prevent injury if an obstruction is encountered. The appropriate stall force settings depend on the gate's length and weight, so fine-tuning may be required. Follow these steps to adjust the stall force:

- ◆ **Initial Assessment:** Use the remote control to open and close the gate, observing its movement.
- ◆ **Adjust the Stall Force:** If the gate reverses or stops before reaching the fully closed or open position, increase the stall force by turning OPEN and CLOSE Potentiometers slightly clockwise.
- ◆ **Perform the Obstruction Test:** Run the test after each force setting adjustment (see below).

Obstruction Test

This test ensures that the gate opener's automatic obstruction-sensing feature functions correctly. The gate should have enough force to reach both open and close limits, but **MUST** stop or reverse after contacting with a solid object.

- ◆ **Operate the Gate:** Open and close the gate with the remote control, ensuring that it stops at the proper open and close limit positions.
- ◆ **Setup for the Test:** Place a solid, immovable object in the gate's path to simulate an obstruction.
- ◆ **Test Gate's Closing:** Run the gate in the closing direction towards the obstruction. The gate should reverse upon contact with the solid object. If it does not, slightly decrease the stall force by turning CLOSE Potentiometer on the control board counterclockwise (towards MIN).
- ◆ **Test Gate's Opening:** Perform the same test with the gate moving in the opening direction. The gate should stop upon contact with the solid object. If it does not, slightly decrease the stall force by turning OPEN Potentiometer on the control board counterclockwise (towards MIN).

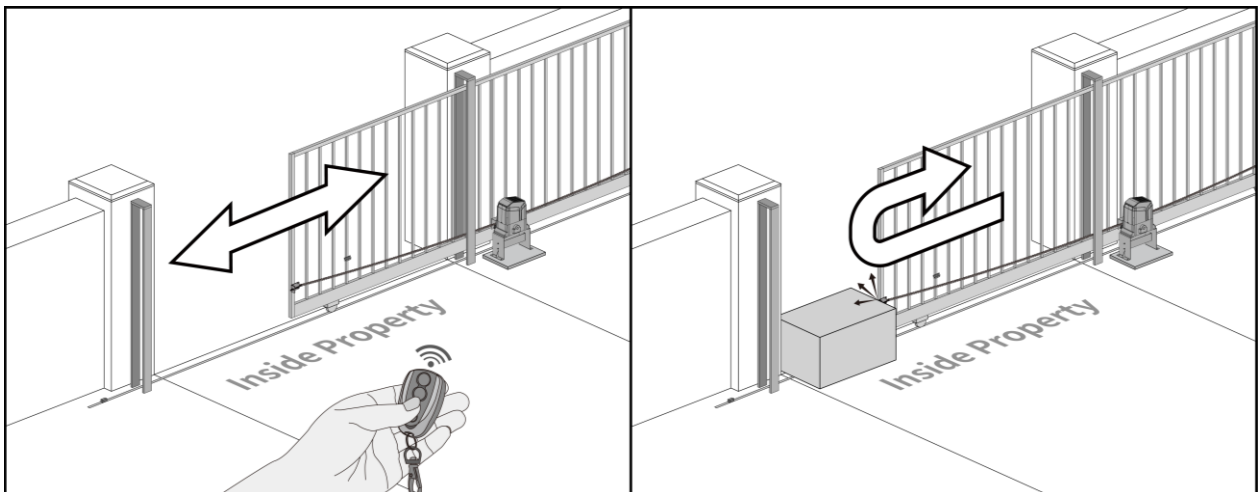

NOTES:

- ◆ *If the stall force is set too low (i.e., the sensitivity is too high), the gate may stop or reverse too easily, even with minimal obstruction or resistance, such as strong wind or heavy snow.*
- ◆ *The gate opener is designed to reverse the gate when the gate comes in contact with an obstruction during closing and to stop the gate during opening. It is highly recommended to install a photocell sensor for additional safety.*
- ◆ *Always perform an obstruction test for the gate each time you set up the control board or restart it after a power outage.*

Connection of Accessories

NOTES

- ◆ This section covers only the programming and wire connections with the control board. For additional operations, please refer to the corresponding accessory user manual.
- ◆ It is highly recommended to install a photocell sensor in the following situations for safety: if you have children or pets at your property, the gate opener auto close function is set to ON, the gate opener stall force is set to the maximum, a vehicle exit sensor is installed, or other gate control devices are used.

TC188 Universal Keypad

Operate the gate using a user-defined password. You can use this keypad wirelessly or wire it to the gate opener according to your needs.

Wireless Mode Programming and Operation

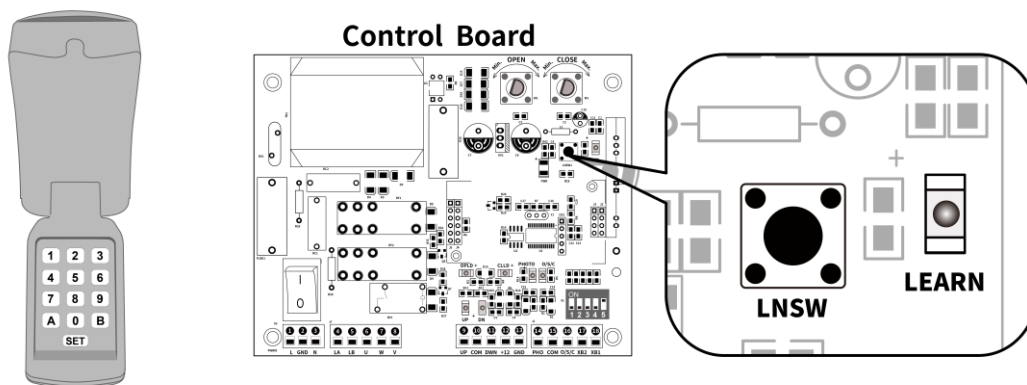

Step 1 Program New Master Code

Factory default master code is 9999, all codes should be 4 digits in length.

SET 4 digits Old Master Code SET 01 SET 4 digits New Master Code SET 4 digits New Master Code SET

Step 2 Add New Permanent Entry Code

SET Master Code SET 02 SET Entry Code SET Entry Code SET

Step 3 Program with the Gate Opener

- ◆ Input the entry code of the keypad.
- ◆ Press and release the LNSW button on the control board. The LEARN LED will turn on, indicating that the gate opener is now in programming mode.
- ◆ Press button A (or B) once, and the keypad LED backlight will flash quickly. Press it again after the backlight changes from a rapid flash to a slow flash.
- ◆ The LEARN LED will flash for 3 seconds and then turn off, indicating successful programming.

Step 4 Operate the Gate Opener

Input the entry code and then press the programmed button A (or B) to operate the gate. Within 3 seconds of pressing button A (or B), you can press the button again without re-entering the code to operate the gate.

Connection of Accessories

Wired Mode Connection and Operation

Step 1 Remove the Battery

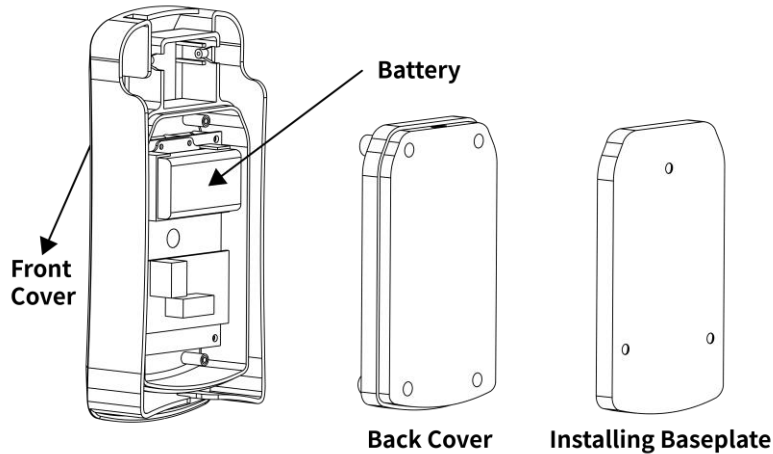

Step 2 Wire Connection

Connect the “COM” and “NO” terminals to control board terminal ⑮ “COM” and terminal ⑯ “O/S/C”. Then connect the “9-24V AC/DC” terminals to control board terminal ⑫ “+12” and terminal ⑬ “GND”. Polarity does not matter for these connections.

NOTE: A 4C x 0.3 mm² (22AWG) cable is required for the wire connection, but it is NOT included.

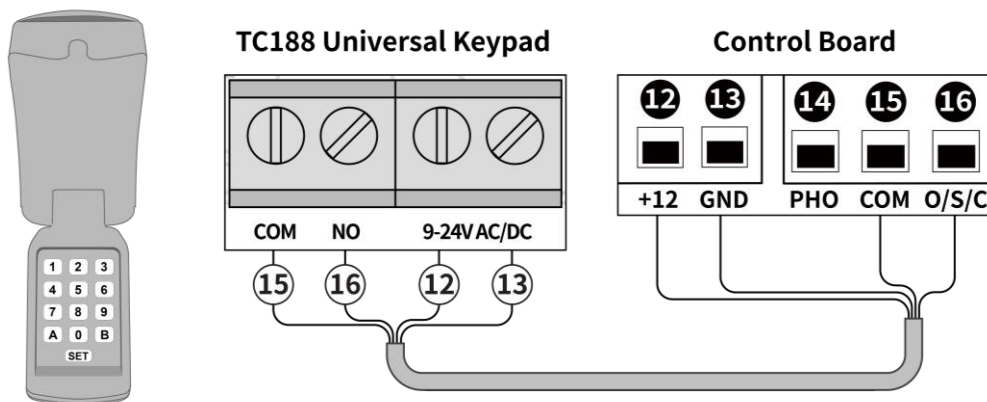

Step 3 Program New Master Code

Factory default master code is 9999, all codes should be 4 digits in length.

SET 4 Digits Old Master Code SET 01 SET 4 Digits New Master Code SET 4 Digits New Master Code SET

Step 4 Add New Permanent Entry Code

SET Master Code SET 02 SET Entry Code SET Entry Code SET

Step 5 Operate the Gate Opener

Input the entry code and then press button A (or B) to operate the gate. Within 3 seconds of pressing button A (or B), you can press the button again without re-entering the code to operate the gate.

Connection of Accessories

TKP3 Wireless Keypad

Operate the gate with a user defined password

Programming and Operation

- ◆ Press and release the LNSW button on the control board. The LEARN LED will turn on, indicating that the gate opener is now in programming mode.
- ◆ Press the button “OK” on the keypad and the LEARN LED will flash for 3 seconds and then turn off, indicating successful programming.
- ◆ Use the default password “888888” to operate the gate opener. Press “PIN” “8 8 8 8 8 8” and then press the button “OK” to operate the opener. Just one press of the button “OK”, the moving gate will stop for quick passing through.

Change the Password

- ◆ Press “PIN”, input the old six digits password, and then press the “PIN” again, the LEARN LED will be ON.
- ◆ Input the new six digits password and then press the “PIN” to confirm the new setting, LEARN LED will flash for 3 seconds and then turn off which indicates the password has been changed successfully.
- ◆ Press “PIN” “new six digits password” and then press the button “OK” to operate the gate opener.



The keypad is oval-shaped with a circular display area containing a numeric keypad (1-9, 0, PIN, OK) and a central LNSW button.

Program the Keypad

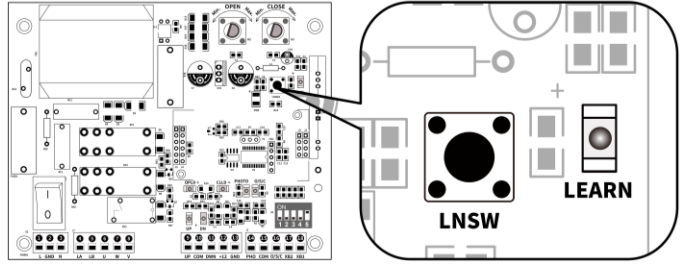

The diagram shows the control board with the LNSW button and LEARN LED highlighted. A callout shows the LNSW button and LEARN LED in detail.

Use the Default Password

PIN 888888 OK

Change the Password

PIN Old Six Digits Password PIN
New Six Digits Password PIN

Use the New Password

PIN New Six Digits Password OK

NOTES:

- ◆ Each button press during programming must be completed within 1 second to ensure successful programming.
- ◆ If you forget the password, you can reset the keypad to restore the default code "888888" by reprogramming it.

Connection of Accessories

TC173 Wireless Push Button

Open / close the gate by pressing the wireless button

Programming and Operation

- ◆ Press and release the LNSW button on the control board. The LEARN LED will turn on, indicating that the gate opener is now in programming mode.
- ◆ Press the push button once, then press it again after the LED on the push button turns off. The LEARN LED will flash for 3 seconds and then turn off, indicating successful programming.
- ◆ Each press of the button will cycle the gate through open, stop, close, stop, and open.

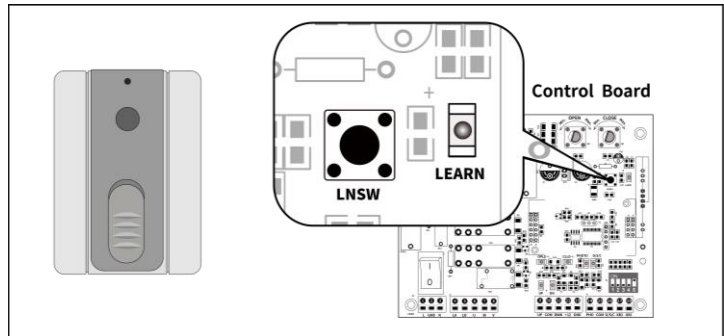

TC196 Tuya WiFi Remote Control

- ◆ Control the gate opener with your cellphone anytime and anywhere when the remote controller is connected with WiFi.
- ◆ Please see detailed connection steps in TC196 user manual.

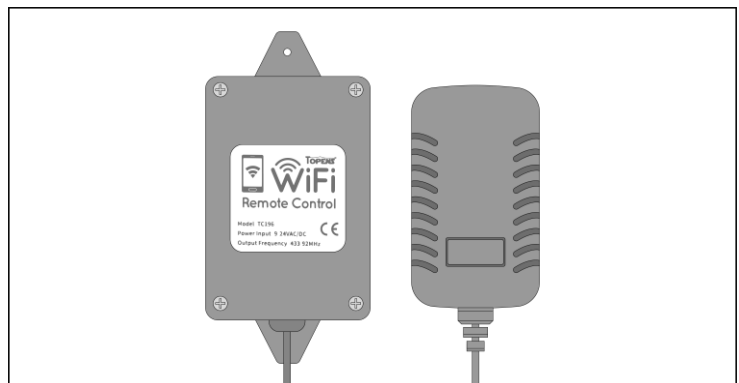

Connection of Accessories

TEW3 Vehicle Sensor Exit Wand

Opens the gate automatically when it senses an approaching car

Wire Connection

- ◆ Connect the RED wire to control board terminal ⑫ “+12” .
- ◆ Connect the GREEN wire to control board terminal ⑬ “GND” .
- ◆ Connect the BLUE wire to control board terminal ⑰ “XB2” .
- ◆ Connect the BLACK wire to control board terminal ⑱ “XB1” .
- ◆ The sensitivity range adjustment board should be wired to the GREEN and YELLOW wires of the wand, regardless of the polarity.
- ◆ The exit wand adapter board must be inserted into the gate opener control board before using.

Key Installation Notes

- ◆ Install the wand 7.5m to 30m (25ft. to 100ft.) away from the gate, and bury it 5cm (2") deep from ground and 20cm (8") from the driveway edge.
- ◆ Install the wand away from any power lines to avoid interrupting the detection signal.
- ◆ It is strongly recommended to enable the auto close function by referring to the Setting of the Control Board section in the installation manual to ensure home security.

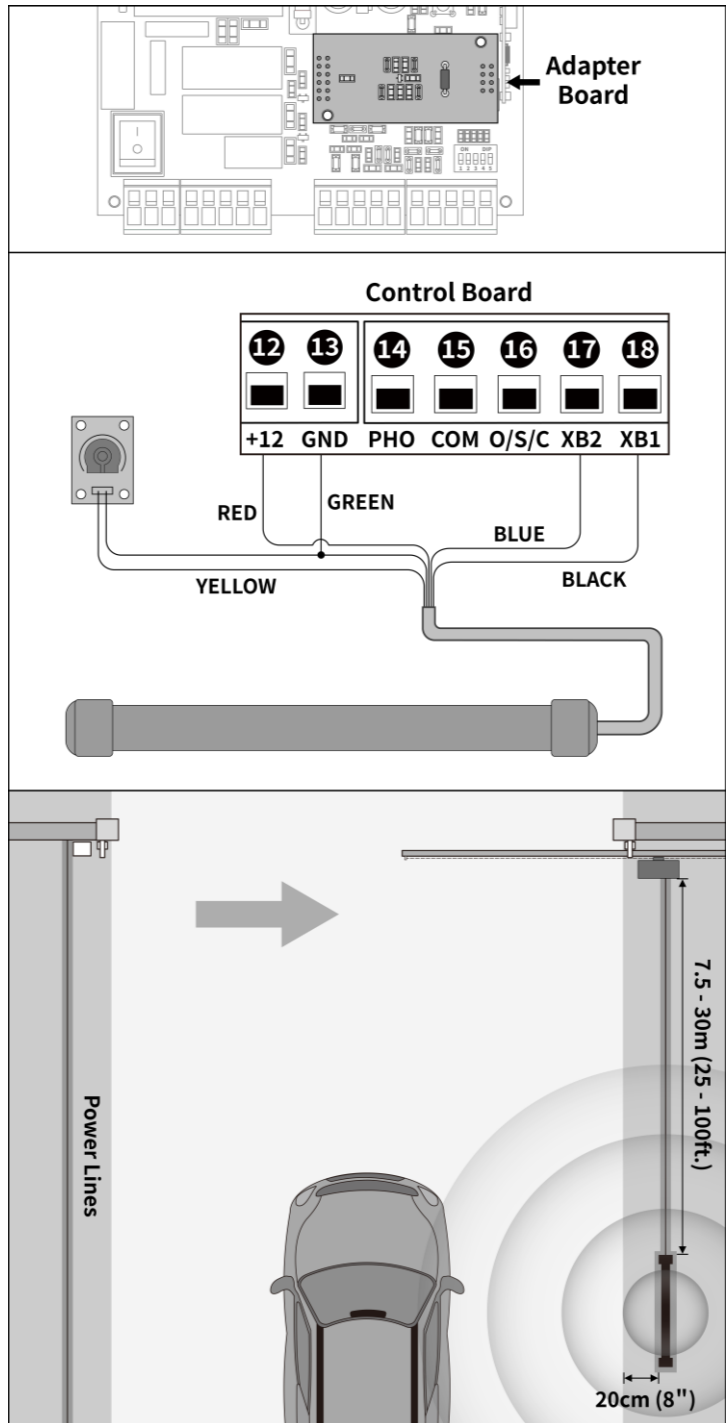

Connection of Accessories

TC175P Wired Keypad

Operate the gate with a user defined password / ID card

Wire Connection

- ◆ Connect the wires on the JP2 terminal of the wired keypad to the control board.
- ◆ Connect the RED wire to control board terminal ⑫ “+12” .
- ◆ Connect the BLACK wire to control board terminal ⑬ “GND” .
- ◆ Connect the BLUE wire to control board terminal ⑮ “COM” .
- ◆ Connect the PURPLE wire to control board terminal ⑯ “O/S/C” .

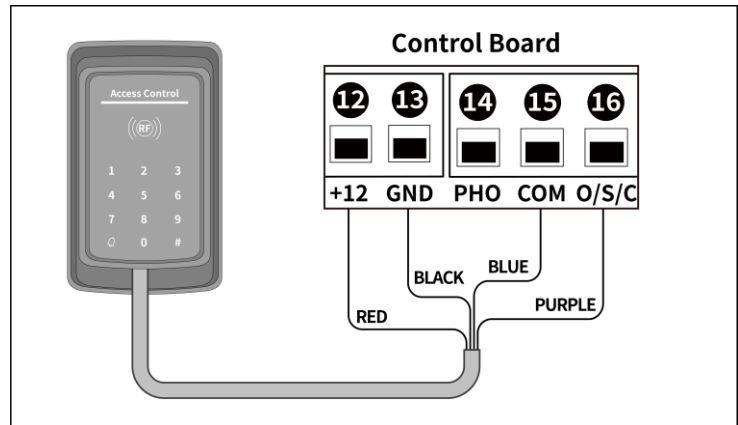

NOTES:

- ◆ A 4C x 0.3 mm² (22AWG) cable is required for the wire connection, but it is NOT included.
- ◆ Please see detailed password setting steps in TC175P user manual.

HLR01 Homelink Remote Control Kit

Links the gate opener with your car's Homelink system, allows for easy control of the gate opener through the Homelink system.

Wire Connection

- ◆ Connect terminal ① to control board terminal ⑮ “COM” .
- ◆ Connect terminal ② to control board terminal ⑯ “O/S/C” .
- ◆ Connect terminal ⑦ “+DC” to control board terminal ⑫ “+12” .
- ◆ Connect terminal ⑧ “DC-” to control board terminal ⑬ “GND” .

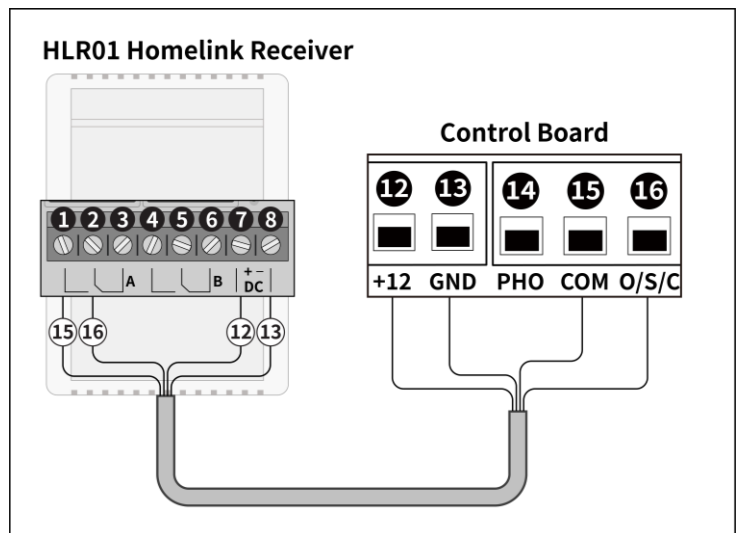

NOTES:

- ◆ A 4C x 0.3 mm² (22AWG) cable is required for the wire connection, but it is NOT included.
- ◆ Please see detailed programming steps with Homelink system in HLR01 user manual.

Connection of Accessories

JD110VY Warning Light

Flashing when the gate is moving, improving your gate safety

Wire Connection

- ◆ Connect the warning light to control board terminal ④ “LA” and terminal ⑤ “LB”, regardless of the polarity.

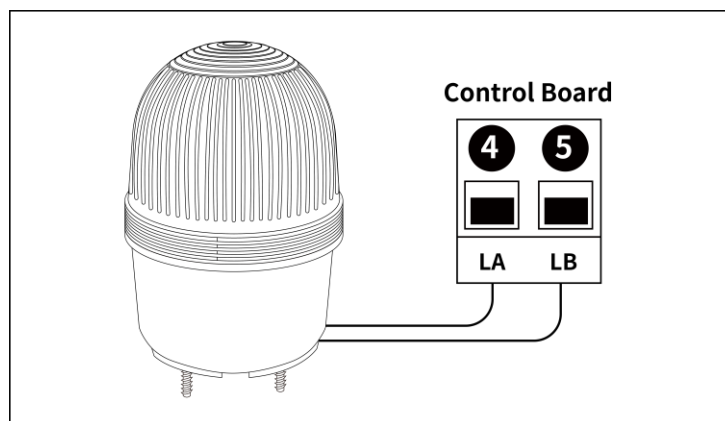

NOTE: A 2C x 0.3 mm² (22AWG) cable is required for the wire connection, but it is NOT included.

TRF3 Reflection Photocell Sensor

Prevents the gate from closing when obstructed, adds security with simple wire connection

Wire Connection

- ◆ Connect the “ 10-25VAC / 12-30VDC” terminals to control board terminal ⑫ “+12” and terminal ⑬ “GND”, regardless of the polarity.
- ◆ Connect the “NO” terminal to control board terminal ⑭ “PHO”, connect the “COM” terminal to control board terminal ⑮ “COM”.

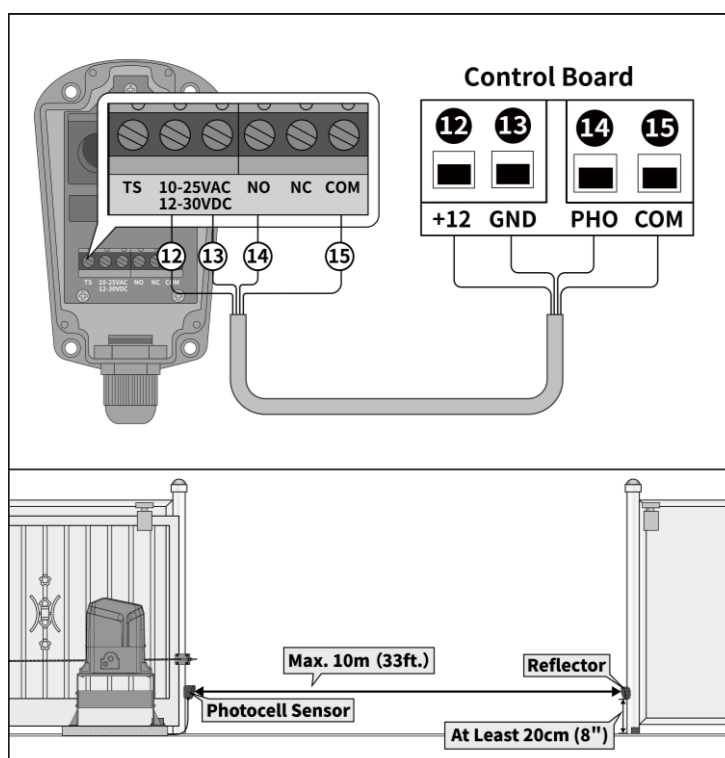

Key Installation Notes

- ◆ Mount the photocell sensor at least 20cm (8") above the ground.
- ◆ Power on the gate opener. Position the reflector directly opposite the mounted photocell sensor. The working light on the photocell sensor turning green indicates that the reflector is in the correct position.
- ◆ The maximum sensing range of the photocell sensor is 10m (33ft.).

NOTE: A 4C x 0.3 mm² (22AWG) cable is required for the wire connection, but it is NOT included.

Connection of Accessories

TC102 Infrared Photocell Sensor

Prevents the gate from closing when obstructed, adds security

Wire Connection

- ◆ For the emitter, connect the “~ +” terminal to control board terminal ⑫ “+12”, connect the “~ -” terminal to control board terminal ⑬ “GND” .
- ◆ For the receiver, connect the “~ +” terminal to control board terminal ⑫ “+12”, connect the “~ -” terminal to control board terminal ⑬ “GND” . Connect the “NO” terminal to control board terminal ⑭ “PHO”, connect the “COM” terminal to control board terminal ⑮ “COM” .

Key Installation Notes

- ◆ Mount the photocell sensor at least 20cm (8") above the ground.
- ◆ Place the receiver on the control box side of the gate opener, directly facing the emitter.
- ◆ Ensure that both the emitter and receiver are aligned with each other. If manual precise alignment is difficult, use a visible laser beam for assistance.
- ◆ The maximum sensing range is 20m (65ft.), and the recommended distance between the emitter and receiver is 3m to 14m (10ft. to 46ft.).
- ◆ Put the cables into PVC conduit and bury the conduit underground to prevent damage.

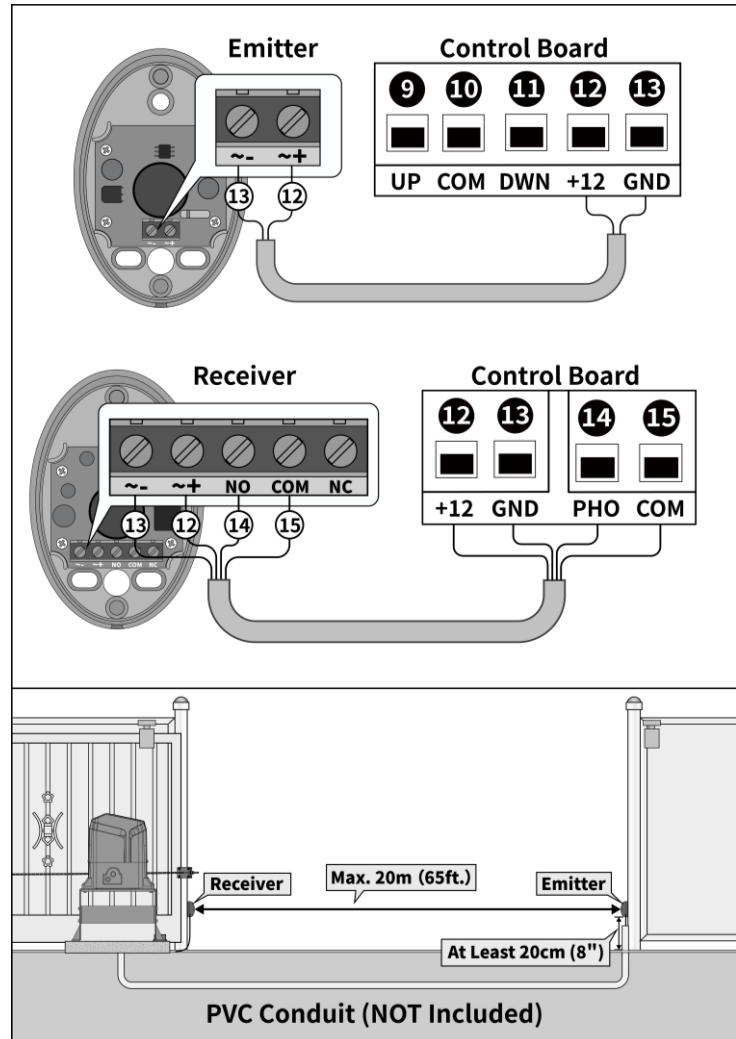

NOTE: Connect the emitter to the gate opener with a 2C x 0.3 mm² (22AWG) cable. Connect the receiver to the gate opener with a 4C x 0.3 mm² (22AWG) cable. Cables are required but NOT included.

Connection of Accessories

ERM12 External Receiver

Allows up to 250 remotes to be programmed with the gate opener

Wire Connection

- ◆ Connect the RED wire to control board terminal ⑫ “+12” .
- ◆ Connect the BLACK wire to control board terminal ⑬ “GND” .
- ◆ Connect the BROWN wire to control board terminal ⑯ “O/S/C” .

Program the Remote Control with the Receiver

- ◆ Before programming, ensure the M12 remote control has been erased from the control board to avoid conflicts.
- ◆ Press and release the Learn Button on the receiver, the LED light will turn ON. Press the remote control button you want to program once, then press it again after the LED on the remote turns off.
- ◆ The LED Light on the receiver will flash for 3 seconds and then turn OFF indicating successfully programming.

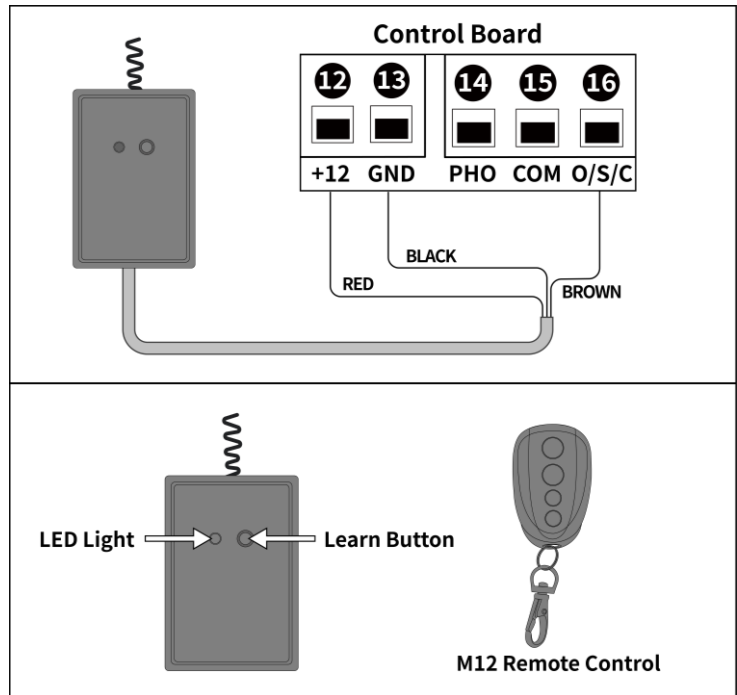

TC148 Waterproof Wall Push Button & TC147 Wall Push Button

Open / close the gate by pressing the wired button

Wire Connection

- ◆ Connect the push button to control board terminal ⑮ “COM” and terminal ⑯ “O/S/C” , regardless of the polarity.
- ◆ Each press of the button will cycle the gate through open, stop, close, stop, and open.

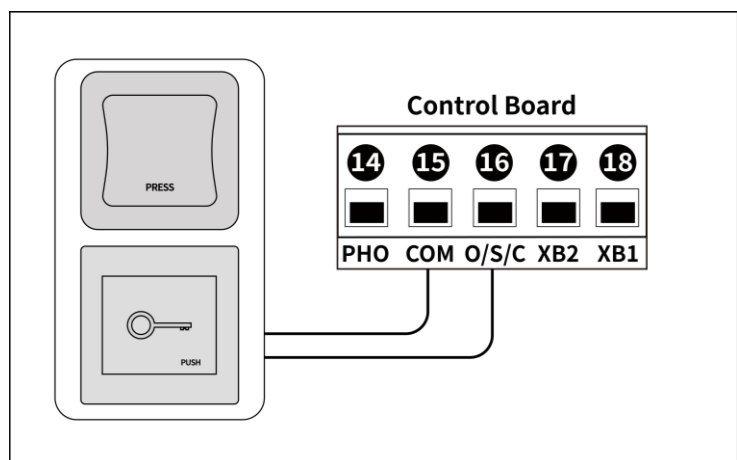

NOTE: A 2C x 0.3 mm² (22AWG) cable is required for the wire connection, but it is NOT included.

Maintenance and Replacement Parts

Maintenance

WARNING

Disconnect the AC power to the gate opener before routine inspections and lubrication.

Routine Inspections

- ◆ **Inspect the Gate:** Look for any signs of wear or damage on the gate and guide tracks.
- ◆ **Check the Gate Opener:** Ensure that the opener is securely attached to the concrete pad. Tighten any loose bolts and screws.
- ◆ **Examine Cables and Wires:** Check that all cables and wires are intact and free from corrosion. Ensure that the opener is properly earthed and the wire is securely connected.

Cleaning and Lubrication

Keep the gate opener and the surrounding area clean to prevent the accumulation of dirt, dust, leaves, and debris. Use a clean, dry cloth to wipe the gate opener shafts, gears, and chain, and lubricate them as needed.

Obstruction Test

The gate must stop or reverse upon contact with a solid object. Perform the obstruction test monthly, or whenever you set up the control board or after a power outage. Failure to properly adjust and retest the gate opener can increase the risk of injury or death.

Replacement Parts

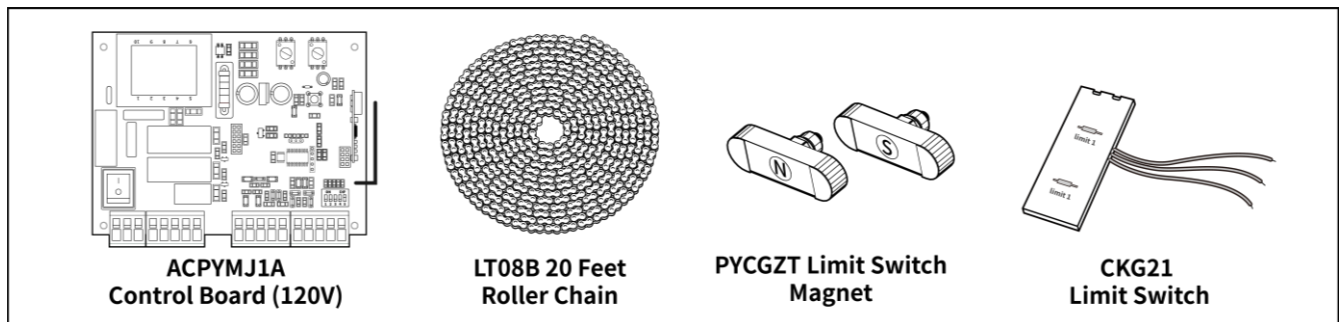

* Available on the TOPENS website (www.topens.com) and Amazon.

Troubleshooting

If your gate opener does not function properly after installation, please follow the steps below before contacting us for assistance. This guide provides common troubleshooting steps to help resolve issues efficiently. For further assistance, please feel free to contact us through our website at www.topens.com.

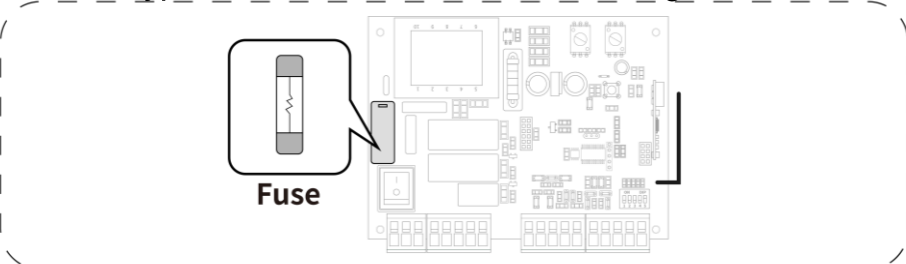
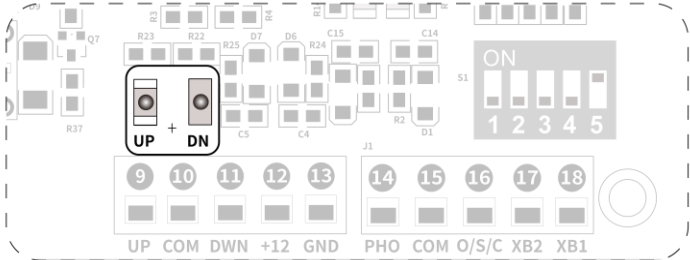
Symptom	Possible Solution(s)
<p>The opener does not run. Power LED is OFF.</p>	<p>Step 1 Check Control Board Input Voltage: Verify that the input voltage of the control board matches the local AC power supply.</p> <p>Step 2 Check the Power Switch: The power switch is OFF. Please ensure that the power switch is turned ON.</p> <p>Step 3 Examine Control Board Fuse: Inspect the control board fuse and replace it with the backup fuse that comes with the gate opener if it is burnt out. <u>The fuse type is Ø5*20mm 10A 250VAC fast blow glass fuse.</u></p>  <p>Step 4 Check Control Board: Inspect the control board and replace it if needed.</p>
<p>The gate opens to the set open position and stops, but it does not return.</p>	<p>Step 1 Verify Magnet Position: Check if the magnet has been installed incorrectly. Adjust the magnet to the correct position as instructed in the manual. Then move the gate to the open and closed positions to check whether the limit switch can detect the magnet, and observe whether the UP and DN LED on the control board turn ON. The UP LED indicates the sensing status of the higher magnet, while the DN LED indicates the sensing status of the lower magnet.</p>  <p>Step 2 Check Limit Switch: Disconnect the limit switch wires from terminal ⑨ “UP” , terminal ⑩ “COM” , and terminal ⑪ “DWN” on the control board. Press the remote to operate the opener. If the motor runs normally in both directions, replace the limit switch. During the test, monitor the gate's movement and use the remote to stop it if necessary to prevent the gate from running off the track.</p> <p>Step 3 Check Control Board: Inspect the control board and replace it if needed.</p>

Troubleshooting

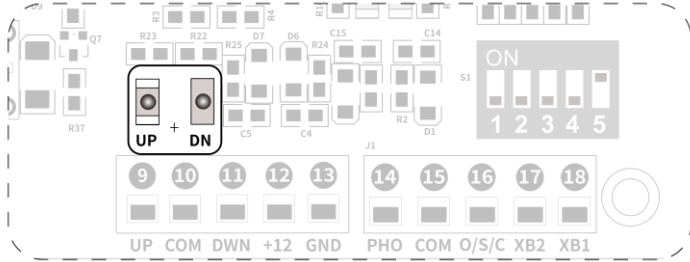
Symptom	Possible Solution(s)
<p>Midway function is disabled.</p>	<p>Step 1 Check DIP Switch Setting: Set DIP Switch #5 to OFF for a left-opening gate and ON for a right-opening gate.</p> <p>Step 2 Verify Magnet Position: Check if the limit switch is properly sensed by the closing magnet when the gate is fully closed. Adjust the magnet's position to ensure accurate sensing. The UP LED indicates the sensing status of the higher magnet, while the DN LED indicates the sensing status of the lower magnet. The LED will turn ON when it senses the magnet.</p>  <p>Step 3 Replace Remote Control: Use a new remote control and test again.</p> <p>Step 4 Check Control Board: Inspect the control board and replace it if needed.</p>
<p>The gate opens but fails to close.</p>	<p>Step 1 Verify Photocell Sensor Function: Check if the photocell sensor is blocked or misaligned. Clear any obstructions, and ensure that the photocell sensor is properly aligned.</p> <p>Step 2 Check Limit Switch: Disconnect the limit switch wires from terminal ⑨ “UP”, terminal ⑩ “COM”, and terminal ⑪ “DWN” on the control board. Press the remote to operate the opener. If the motor runs normally in both directions, replace the limit switch. During the test, monitor the gate's movement and use the remote to stop it if necessary to prevent the gate from running off the track.</p> <p>Step 3 Check Control Board: Inspect the control board and replace it if needed.</p>
<p>One of the remote controls does not work.</p>	<p>Step 1 Check Remote Control Battery: Press the remote and check if the indicator light turns on. If it doesn't, check the battery orientation and ensure the positive side is facing upward. If the polarity is correct, replace the batteries with two 3V CR2025 lithium button cells.</p> <p>Step 2 Check Remote Control Programming: Ensure that the remote control is correctly programmed to the control board. If not, refer to the Program the Remote Control section in this manual to reprogram the remote.</p> <p>Step 3 Check Remote Control Range: The maximum effective range of the remote control is 20 meters (65 feet). Try operating it again from a closer distance.</p>

Troubleshooting

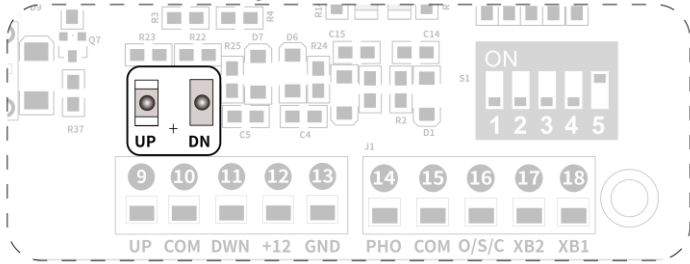
Symptom	Possible Solution(s)
<p>The opener does not run. Power LED is ON.</p>	<p>Step 1 Isolate the Issue with Wired Accessories: Disconnect all wired accessories from the control board. Test the gate operation. If the issue is resolved, reconnect the accessories one by one to identify the problem.</p> <p>Step 2 Check Remote Control Programming: Ensure that the remote control is correctly programmed to the control board. If not, refer to the Program the Remote Control section in this manual to reprogram the remote.</p> <p>Step 3 Check Thermal Protector: Inspect the thermal protector to see if the motor has overheated due to prolonged use. Wait 20 minutes for the motor to cool down.</p> <p>Step 4 Verify Magnet Position: Check if the magnet has been installed incorrectly. Adjust the magnet to the correct position as instructed in the manual. Then move the gate to the open and closed positions to check whether the limit switch can detect the magnet, and observe whether the UP and DN LED on the control board turn ON. The UP LED indicates the sensing status of the higher magnet, while the DN LED indicates the sensing status of the lower magnet.</p>  <p>Step 5 Check Limit Switch: Disconnect the limit switch wires from terminal ⑨ “UP” , terminal ⑩ “COM” , and terminal ⑪ “DWN” on the control board. Press the remote to operate the opener. If the motor runs normally in both directions, replace the limit switch. During the test, monitor the gate's movement and use the remote to stop it if necessary to prevent the gate from running off the track.</p> <p>Step 6 Check Control Board: Inspect the control board and replace it if needed.</p>
<p>The motor runs but the gate does not move.</p>	<p>Step 1 Check the Clutch: Ensure that the clutch for the emergency release is properly adjusted and not slipping.</p>

Troubleshooting

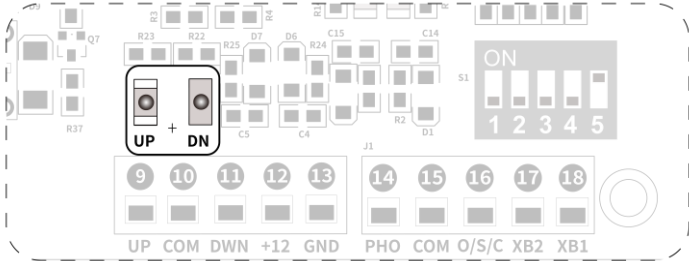
Symptom	Possible Solution(s)
<p>Gate ignores the limit switch.</p>	<p>Step 1 Adjust the Magnet Position: Move the magnets toward the middle position so that the gate opener detects them earlier. Then press the remote to see if the gate stops at the desired position. If it doesn't, proceed to Step 2.</p> <p>Step 2 Check the Limit Switch Indication LED: Release the clutch and press the remote to run the motor. Then move the gate to the open and closed positions to check whether the limit switch can detect the magnet, and observe whether the UP and DN LED on the control board turn ON. The UP LED indicates the sensing status of the higher magnet, while the DN LED indicates the sensing status of the lower magnet. If the LED remains OFF, the magnet is not triggering the limit switch. Please proceed to Step 3.</p>  <p>Step 3 Check the Installation Position of the Magnets: The lower magnet bracket should be installed on the left side and the higher magnet bracket on the right side, as viewed from inside the property. Ensure that both the lower and higher magnets are positioned 20–30mm (0.8–1.2") away from the limit switch box.</p>
<p>The gate opens randomly.</p>	<p>Step 1 Check DIP Switch Setting: Set DIP Switch #5 to OFF for a left-opening gate and ON for a right-opening gate.</p> <p>Step 2 Isolate the Issue with Wired Accessories: Disconnect all wired accessories from the control board. Test the gate operation. If the issue is resolved, reconnect the accessories one by one to identify the problem.</p> <p>Step 3 Reprogram Remote Controls: Clear all existing remote codes from the control board and reprogram the remote controls.</p> <p>Step 4 Check Control Board: Inspect the control board and replace it if needed.</p>



T: 0086-27-8700 1865
E-mail: agc.wuhan@agc-cert.com
Web: Http://www.agc-cert.com

Room 102, 1st-2nd floor of Building 3, Wuhan Jinneng
Windpower Industrial Park, No.9 Zhulin Road, Fozuling
Street, Wuhan East Lake High-tech Development Zone,
China

Attestation of Conformity

Registration No AGC-WH00066220632E2

Applicant Hangzhou Sanford Technology Co., Ltd
Room 106, Building 4, 8 Shengdi Road, Yuhang Town, Hangzhou City, Zhejiang Province,
China

Product Designation Sliding gate opener

Brand Name /

Model / Series Models CK1200

Manufacturer Hangzhou Sanford Technology Co., Ltd
Room 106, Building 4, 8 Shengdi Road, Yuhang Town, Hangzhou City, Zhejiang Province,
China

Requirement	Applied Standards	Document Evidence	Result
EMC Directive	EN 55014-1:2017+A11:2020 EN 55014-2:2015 EN IEC 61000-3-2:2019 EN 61000-3-3:2013+A1:2019	Test Report: AGC-WH00066220632EE01	Conform



Bram Wu
Signed by General Manager(Bram Wu)
Issue Date: August 16, 2022

This Attestation of Conformity is recognized by Attestation of Global Compliance (Wuhan) Co., Ltd. and made in accordance with the Electromagnetic Compatibility (EMC) Directive 2014/30/EU. The attestation doesn't imply assessment of the production. The Applicant of the attestation is authorized to use this attestation in connection with EC declaration of conformity to the Directive. The attestation is only applicable to the equipments described above. This attestation shall not be re-produced except in full without the written approval of Attestation of Global Compliance (Wuhan) Co., Ltd.

Note: This attestation is part of the full test report(s) and should be used in conjunction with it.

Version: 1.0



T: 0086-27-8700 1865
 E-mail: agc.wuhan@agc-cert.com
 Web: Http://www.agc-cert.com

Room 102, 1st-2nd floor of Building 3, Wuhan Jinneng
 Windpower Industrial Park, No.9 Zhulin Road, Fozuling
 Street, Wuhan East Lake High-tech Development Zone,
 China

Attestation of Conformity

Registration No. AGC-WH00066220632S4

Applicant Hangzhou Sanford Technology Co., Ltd.
 Room 106, Building 4, 8 Shengdi Road, Yuhang Town, Hangzhou City, Zhejiang
 Province, China

Product Designation Sliding gate opener

Brand Name /

Model / Series Models CK1200

Manufacturer Hangzhou Sanford Technology Co., Ltd.
 Room 106, Building 4, 8 Shengdi Road, Yuhang Town, Hangzhou City, Zhejiang
 Province, China

Requirement	Applied Standards	Document Evidence	Result
LVD Directive	EN 60335-2-103:2015, EN 60335-1:2012+ A11:2014 +A13:2017+ A1:2019+A2:2019+ A14:2019 EN 62233:2008	Test Report: AGC-WH00066220632ES01	Conform



Bran Wu

Signed by General Manager(Bran Wu)
 Issue Date: August 9, 2022



This Attestation of Conformity is recognized by Attestation of Global Compliance (Wuhan) Co., Ltd. and made in accordance with the Low Voltage Directive 2014/35/EU. The attestation doesn't imply assessment of the production. The Applicant of the attestation is authorized to use this attestation in connection with EC declaration of conformity to the Directive. The attestation is only applicable to the equipments described above. This attestation shall not be re-produced except in full without the written approval of Attestation of Global Compliance (Wuhan) Co., Ltd.

Note: This attestation is part of the full test report(s) and should be used in conjunction with it.

Version: 1.0



T: 0086-27-8700 1865
E-mail: agc.wuhan@agc-cert.com
Web: Http://www.agc-cert.com

Room 102, 1st-2nd floor of Building 3, Wuhan Jinneng
Windpower Industrial Park, No.9 Zhulin Road, Fozuling
Street, Wuhan East Lake High-tech Development Zone,
China

Attestation of Conformity

Registration No AGC-WH00066220632E2

Applicant Hangzhou Sanford Technology Co., Ltd
Room 106, Building 4, 8 Shengdi Road, Yuhang Town, Hangzhou City, Zhejiang Province,
China

Product Designation Sliding gate opener

Brand Name /

Model / Series Models CK1200

Manufacturer Hangzhou Sanford Technology Co., Ltd
Room 106, Building 4, 8 Shengdi Road, Yuhang Town, Hangzhou City, Zhejiang Province,
China

Requirement	Applied Standards	Document Evidence	Result
Electromagnetic Compatibility Regulations 2016	BS EN 55014-1:2017+A11:2020 BS EN 55014-2:2015 BS EN IEC 61000-3-2:2019 BS EN 61000-3-3:2013+A1:2019	Test Report: AGC-WH00066220632BE01	Conform



Bram Wu
Signed by General Manager(Bram Wu)
Issue Date: August 16, 2022

Recognized by Attestation of Global Compliance (Wuhan) Co., Ltd. in accordance with the Electromagnetic Compatibility Regulations 2016. The attestation doesn't imply assessment of the production. The applicant of the attestation is authorized to use this attestation in connection with UK declaration of conformity to the regulation. The attestation is only applicable to the equipment described above. This attestation shall not be re-produced without the written approval of Attestation of Global Compliance (Wuhan) Co., Ltd.

Note: This attestation is part of the full test report(s) and should be used in conjunction with it.

Version: 1.0



T: 0086-27-8700 1865
E-mail: agc.wuhan@agc-cert.com
Web: Http://www.agc-cert.com

Room 102, 1st-2nd floor of Building 3, Wuhan Jinneng
Windpower Industrial Park, No.9 Zhulin Road, Fozuling
Street, Wuhan East Lake High-tech Development Zone,
China

Attestation of Conformity

Registration No. AGC-WH00066220632B4

Applicant Hangzhou Sanford Technology Co., Ltd.
Room 106, Building 4, 8 Shengdi Road, Yuhang Town, Hangzhou City, Zhejiang
Province, China

Product Designation Sliding gate opener

Brand Name /

Model / Series Models CK1200

Manufacturer Hangzhou Sanford Technology Co., Ltd.
Room 106, Building 4, 8 Shengdi Road, Yuhang Town, Hangzhou City, Zhejiang
Province, China

Requirement	Applied Standards	Document Evidence	Result
Electrical Equipment (Safety) Regulations 2016	BSEN 60335-2-103:2015, BSEN 60335-1:2012+ A11:2014+A13:2017+ A1:2019+A2:2019+ A14:2019 BSEN 62233:2008	Test Report: AGC-WH00066220632BS01	Conform



Signed by General Manager(Bram Wu)
Issue Date: August 9, 2022

Recognized by Attestation of Global Compliance (Wuhan) Co., Ltd. in accordance with the Electrical Equipment (Safety) Regulations 2016. The attestation doesn't imply assessment of the production. The applicant of the attestation is authorized to use this attestation in connection with UK declaration of conformity to the regulation. The attestation is only applicable to the equipment described above. This attestation shall not be re-produced without the written approval of Attestation of Global Compliance (Wuhan) Co., Ltd.
Note: This attestation is part of the full test report(s) and should be used in conjunction with it. Version: 1.0

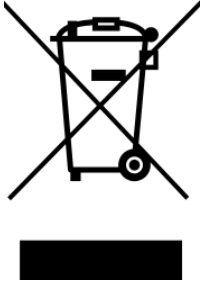

According to Waste of Electrical and Electronic Equipment (WEEE) directive, WEEE should be separately collected and treated. If at any time in future you need to dispose of this product, please do NOT dispose of this product with household waste. Please send this product to WEEE collecting points where available.

Feedback & Review

Your comments and suggestions are important to us
as they help us provide the best possible service.

Should you have any need to contact us, the info below will help you get in touch:



TOPENS Website

www.topens.com

Contact Us:

E-mail: support@topens.com

Kindly include your purchase channel, order #, gate information, issue description and your contact information. All your concerns will be replied within 24 hours.

Tel: +1 (888) 750 9899 (Toll Free USA & Canada)